



2h

PART-NO.: 66602ADE00

GENUINE ACCESSORIES

PARKING DISTANCE CONTROL - FRONT -

- GB** Installation instructions
- DE** Einbauanleitung
- FR** Instructions de montage
- NL** Inbouwhandleiding
- DK** Monteringsvejledning
- IT** Istruzioni per il montaggio
- NO** Montage vejledning
- PT** Instruções de montagem
- ES** Instrucciones de montaje
- SE** Montageanvisning
- CZ** Návod k instalaci
- FI** Asennusohjeet
- PL** Instrukcja instalacji
- RU** Инструкции по монтажу
- SK** Pokyny pre montáž

PRE-INSTALLATIONS CAUTIONS/NOTES:

GB

We would expressly point out that assembly not carried out properly by a competent installer will result in cancellation of any right to damage compensation, especially the right required by the laws in terms of warranty.

Contents of these kits and their fitting manuals are subject to alteration without notice, please ensure that these instructions are read and fully understood before commencing installation.

DE

Beachten Sie bitte, dass bei Schäden in Folge unsachgemäßen Einbaus sämtliche Garantieansprüche erlöschen, insbesondere solche, die das Produkthaftungsgesetz betreffen.

Das Recht zu Änderungen an Inhalt von Montagesatz und Einbauleitungen ohne Vorankündigung bleibt vorbehalten. Lesen Sie vor dem Einbau diese Anleitung sorgfältig und gewissenhaft durch.

FR

Nous tenons à insister tout particulièrement sur le fait que si ce produit n'est pas correctement assemblé par un technicien compétent, aucun droit de compensation ne sera recevable en cas de dommages, notamment les droits en vertu de la loi concernant la responsabilité à l'égard du garant.

Le contenu de ces kits, ainsi que des guides de montage qui les accompagnent est sujet à modifications sans préavis ; lisez attentivement ces instructions avant de procéder à l'installation.

NL

We zouden expliciet willen benadrukken dat installatie die niet correct wordt uitgevoerd door een bekwaam installateur kan leiden tot het vervallen van elk recht op schadecompensatie, vooral de compensatie op basis van de garantie.

De inhoud van deze kits en de installatiehandleidingen kunnen worden gewijzigd zonder kennisgeving. Zorg er dus voor dat u deze instructies hebt gelezen en volledig begrijpt voordat u met de installatie begint.

DK

Det skal understreges, at montering, der udføres af en ikke-kvalificeret montør, medfører bortfald af enhver ret til erstatning særligt i forbindelse med erstatningskrav, der måtte opstå i kraft af loven om produkt garanti.

Sættens indhold og monteringsvejledninger kan ændres uden varsel, og vejledningerne skal derfor læses og forstås, før monteringen påbegyndes.

IT

Facciamo espressamente notare che il montaggio non corretto eseguito da un installatore competente comporterà la cancellazione di qualsiasi diritto di risarcimento danni da parte dell'utente, in particolare il diritto previsto dalle leggi in termini di garanzia.

I contenuti di questi kit e i relativi manuali di installazione sono soggetti a modifica senza preavviso. Si raccomanda di leggere attentamente e integralmente tali istruzioni e di sincerarsi di averle comprese prima di procedere all'installazione.

NO

Vi bemerker at montasje som ikke utføres korrekt, av en kompetent installatør, vil resultere i annullering av all rett til erstatning for enhver skade, spesielt de som oppstår garanti.

Innholdene i disse sett og deres monteringsanvisninger kan endres uten forvarsel. Vennligst påse at disse instruksjonene leses grundig og er forstått innen installasjonsnotene.

PT

Gostaríamos de ressaltar expressamente que a montagem não realizada corretamente por um instalador competente irá resultar no cancelamento de qualquer direito a indemnização de danos, nomeadamente as que decorrem por virtude do acto de responsabilidade do garantia.

Índice desses kits e seus manuais de montagem estão sujeitos a alteração sem aviso prévio, certifique-se que as instruções são lidas e completamente entendidas antes de começar a instalação.

ES

Una vez más, hacemos hincapié en el hecho de que si este producto no lo monta correctamente un técnico instalador cualificado, se anulará cualquier derecho de compensación por posibles daños, especialmente los relativos a la legislación vigente sobre este tipo de garantía.

El contenido de los kits y sus correspondientes manuales de montaje están sujetos a posibles modificaciones sin previo aviso. Es importante que lea con atención todas las instrucciones y que las entienda perfectamente antes de iniciar la instalación.

SE

Vi vill uttryckligen meddela att montering som inte görs fackmannamässigt av en kompetent montör, kommer att häva rätten till kompensation för skador, speciellt rättigheter enligt lagen om produktansvar garanti.

Innehållet i dessa satser och deras bruksanvisningar kan komma att ändras utan föregående meddelande. Vänligen läs dessa anvisningar noga innan du påbörjar monteringen.

CZ

Upozorňujeme, že instalace provedená nesprávně nebo nekompetentní osobou, ruší veškerá práva na kompenzaci škod, obzvláště způsobených poruchou záкура.

Obsah těchto sad a návody na jejich montáž podléhají změnám bez předchozího upozornění. Prosím, ujistěte se, že jste si pokyny před instalací přečetly a dostatečně jim rozumíte.

FI

Jos asennuksen suorittaa joku muu kuin pätevä ammattilainen, tämä kumoo asiakkaan oikeuden vahingonkorvauksiin, erityisesti sellaisiin, jotka perustuvat tuotevastuulakiin.

Kiinnitysasarjan sisältöä ja asennusoppaita voidaan muuttaa sitä etukäteen ilmoittamatta. Asiakkaan tulee ennen asennuksen aloittamista perehtyä huolellisesti näihin ohjeisiin.

PL

Pragniemy zwrócić uwagę na fakt, że nieprawidłowy montaż przeprowadzony przez niekompetentne osoby będzie podstawą do unieważnienia wszelkich praw do odszkodowań, w szczególności wynikających z ustaw o odpowiedzialności za gwarancja.

Zawartość opisywanych zestawów i instrukcje ich montażu mogą ulegać zmianom bez powiadomienia; przed rozpoczęciem instalacji należy zapoznać się z instrukcjami i upewnić się, że zostały zrozumiane.

RU

Обратите при повреждении, возникших в результате неправильного монтажа, истрекают все виды гарантии, в частности, касающиеся закона, регулирующего ответственность за качество продукции гарантия.

Право изменения содержания монтажного комплекта и инструкции по установке без предварительного оповещения производитель оставляет за собой. Внимательно прочитайте инструкцию перед тем, как начать установку.

SK

Pripomíname, že v prípade chybnéj inštalácie vykonanej nekompetentným inštalátorom používateľ stráca akýkoľvek nárok na prípadné odškodnenie ako aj akékoľvek zákonní dané právo týkajúce sa zodpovednosti záruky.

Obsah týchto súprav a príslušné návody na inštaláciu môžu byť zmenené bez predchádzajúceho upozornenia. Odporúčame pozorne si prečítať všetky uvedené pokyny a uistiť sa o ich pochopení ešte pred vykonaním inštalácie.

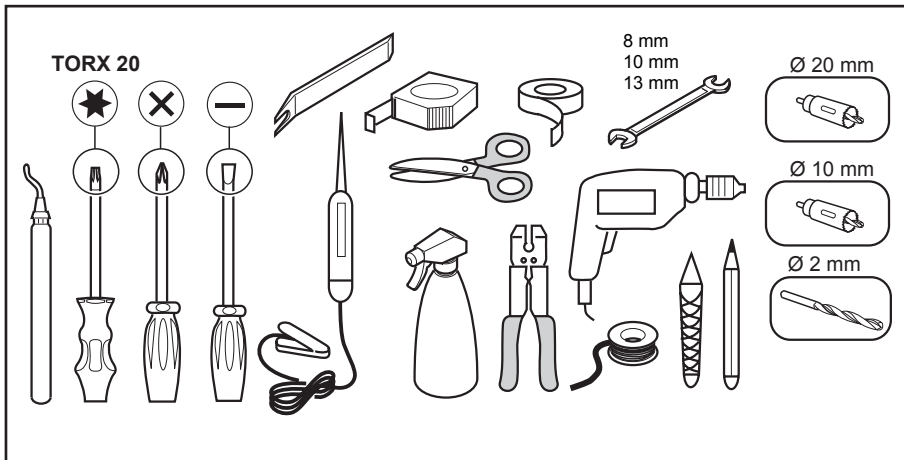

PART LIST - Parking Distance Control (66602ADE00)

GB Part list

DE Einzelteilliste

FR Liste de pieces

NL Onderdelenlijst

DK Del-list

IT Elenco componenti

NO Delliste

PT Lista de peças

ES Lista de componentes

SE Dellista

CZ Seznam dílů

FI Osaluettelo

PL Lista części

RU Список составных частей

SK Zoznam dielov

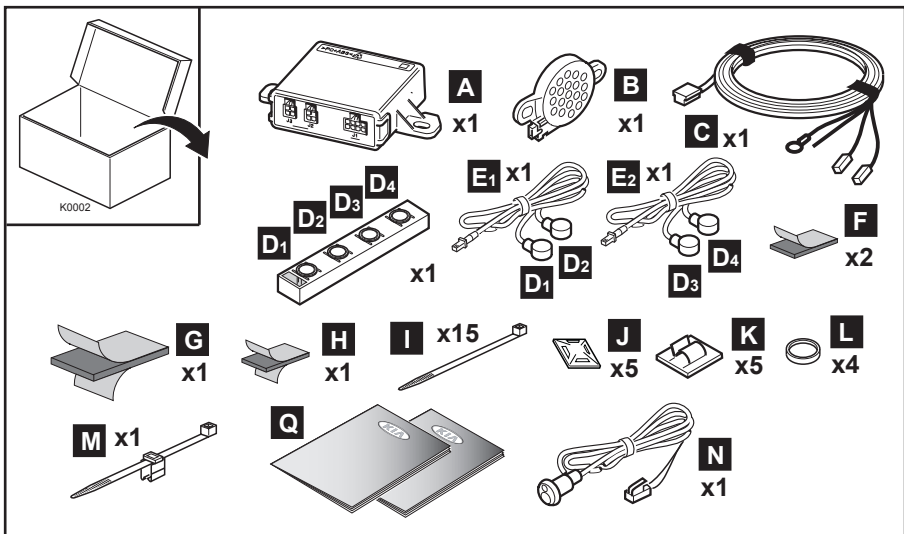

CONNECTIONS - Parking Distance Control (66602ADE00)

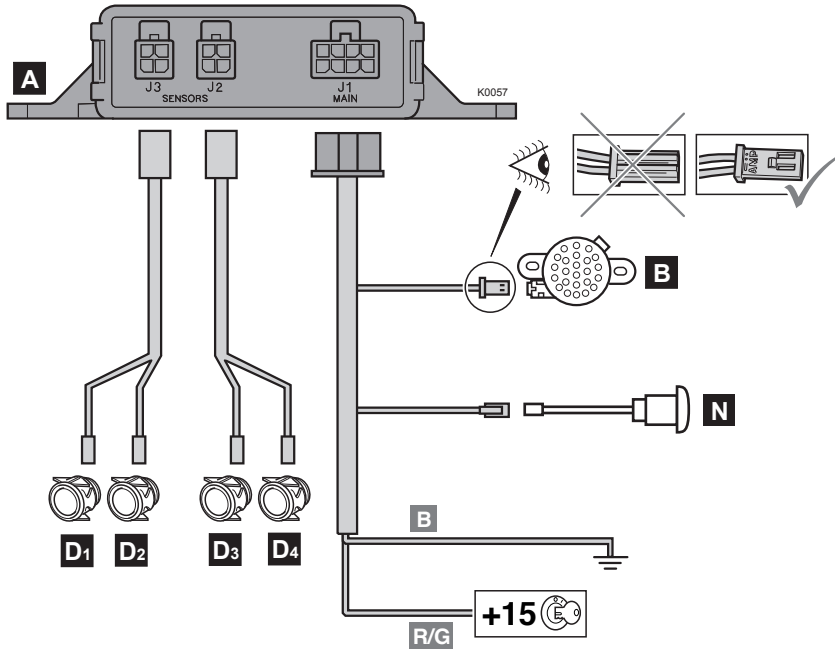

R	RED	ROT	ROUGE	ROOD	ROD	ROSSO	ROD
VERMELHO	ROJO	ROD	ČERVENÁ	PUNAINEN	CZERWONY	КРАСНЫЙ	ČERVENÝ

B	BLACK	SCHWARZ	NOIR	ZWART	SORT	NERO	SVART
PRETO	NEGRO	SVART	ČERNÁ	MUSTA	CZARNY	ЧЕРНЫЙ	ČIERNÝ

G	GREEN	GRÜN	VERT	GROEN	GRØN	VERDE	GRØNN
VERDE	VERDE	GRÖN	ZELENÁ	VIHREÄ	ZIELONA	ЗІЛІН	ZELENÁ

PAINTING - Parking Distance Control (66602ADE00)

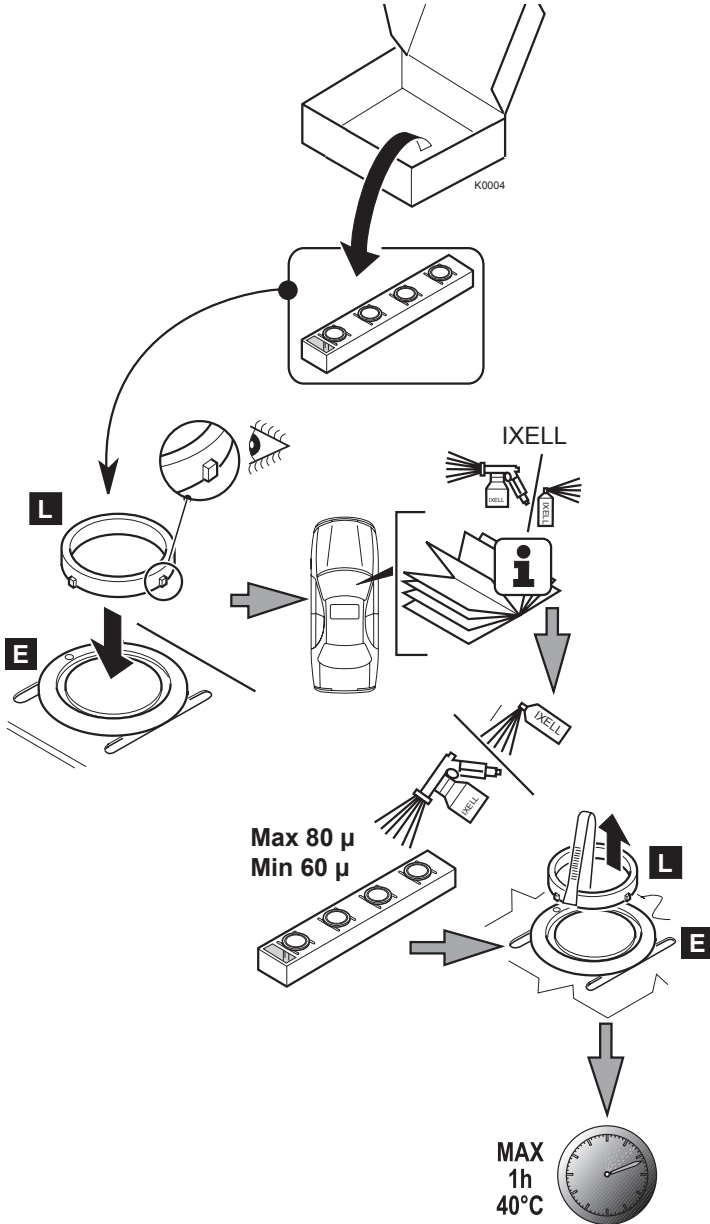



SPECIAL CONFIGURATION

cee'd 5dr + wagon 2012

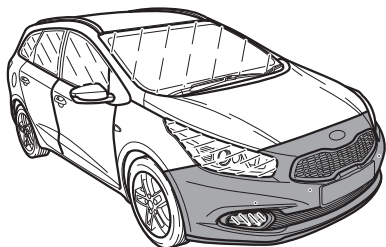

cee'd GT 5dr 2013

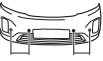
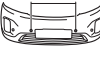

	sensitivity		
 			
1	2	2	4

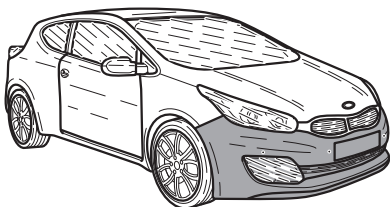

pro_cee'd + cee'd GT 3dr 2013

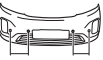
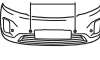

	sensitivity		
 			
1	3	2	4

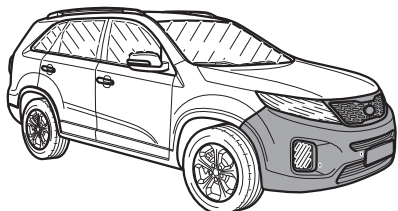
SORENTO 2012



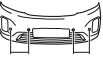
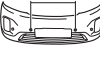



	sensitivity		
 			
1	2	2	4

K0121

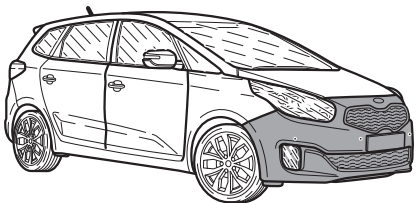
SPECIAL CONFIGURATION

CARENS 2013

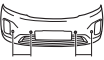

	sensitivity		
1	3	2	4

K0159

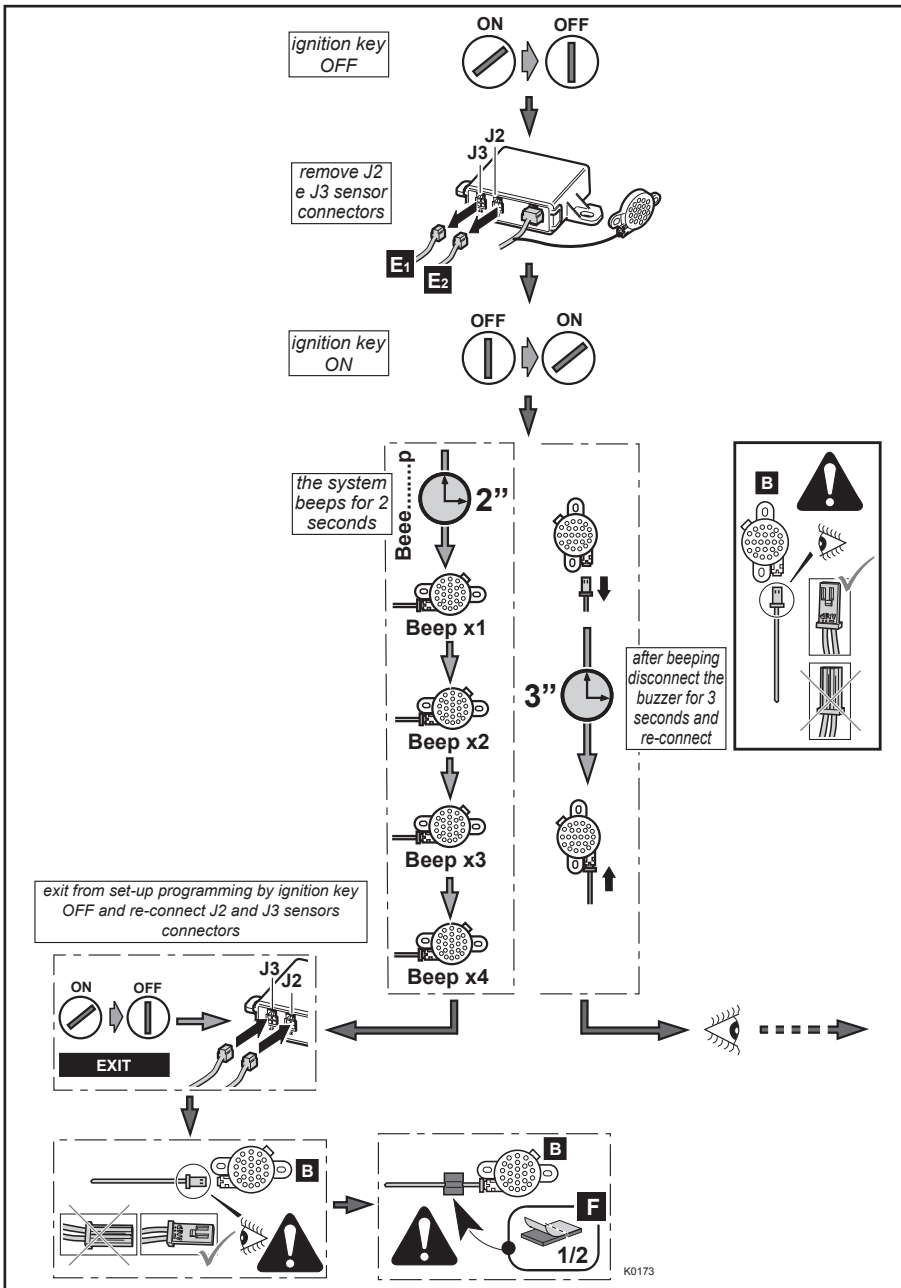

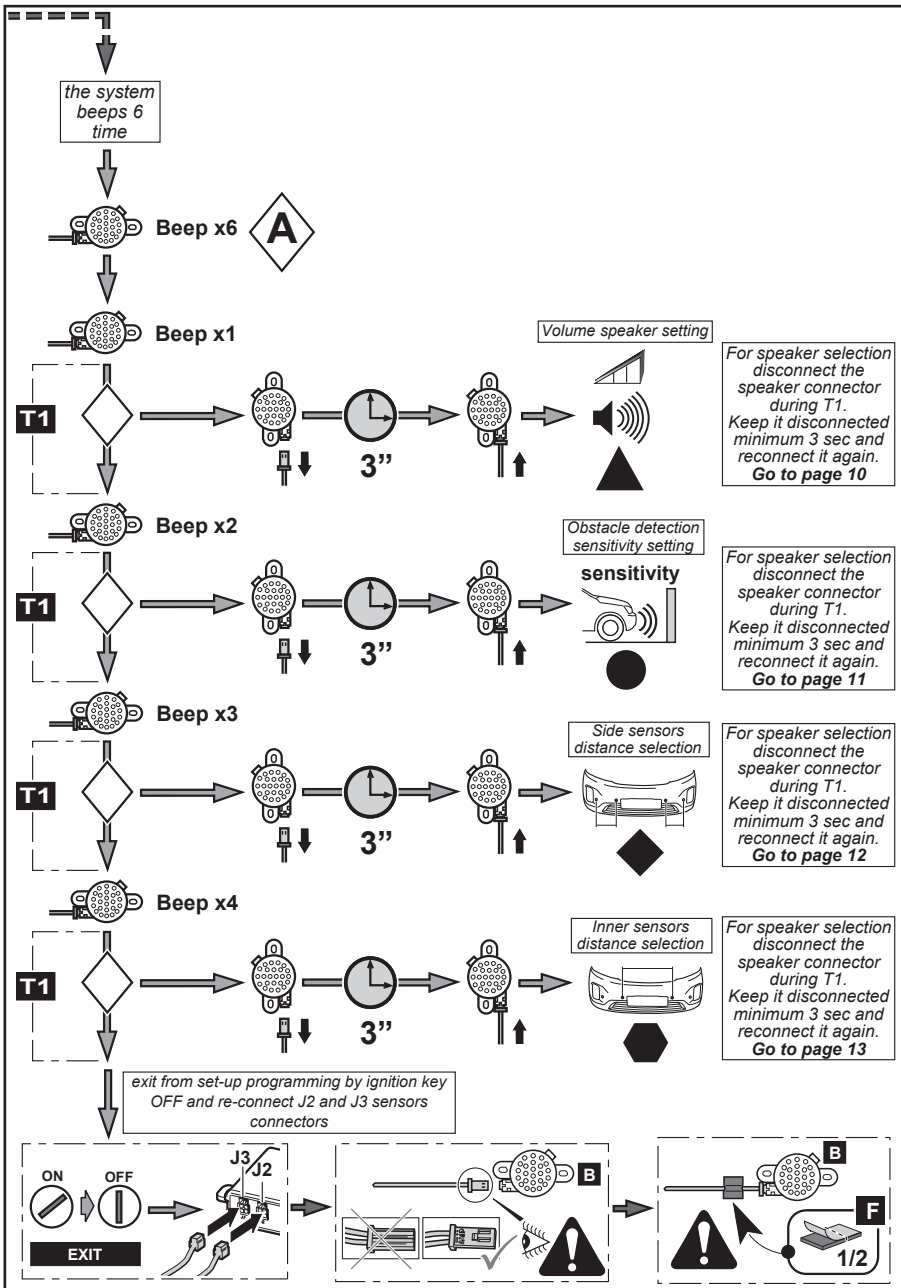

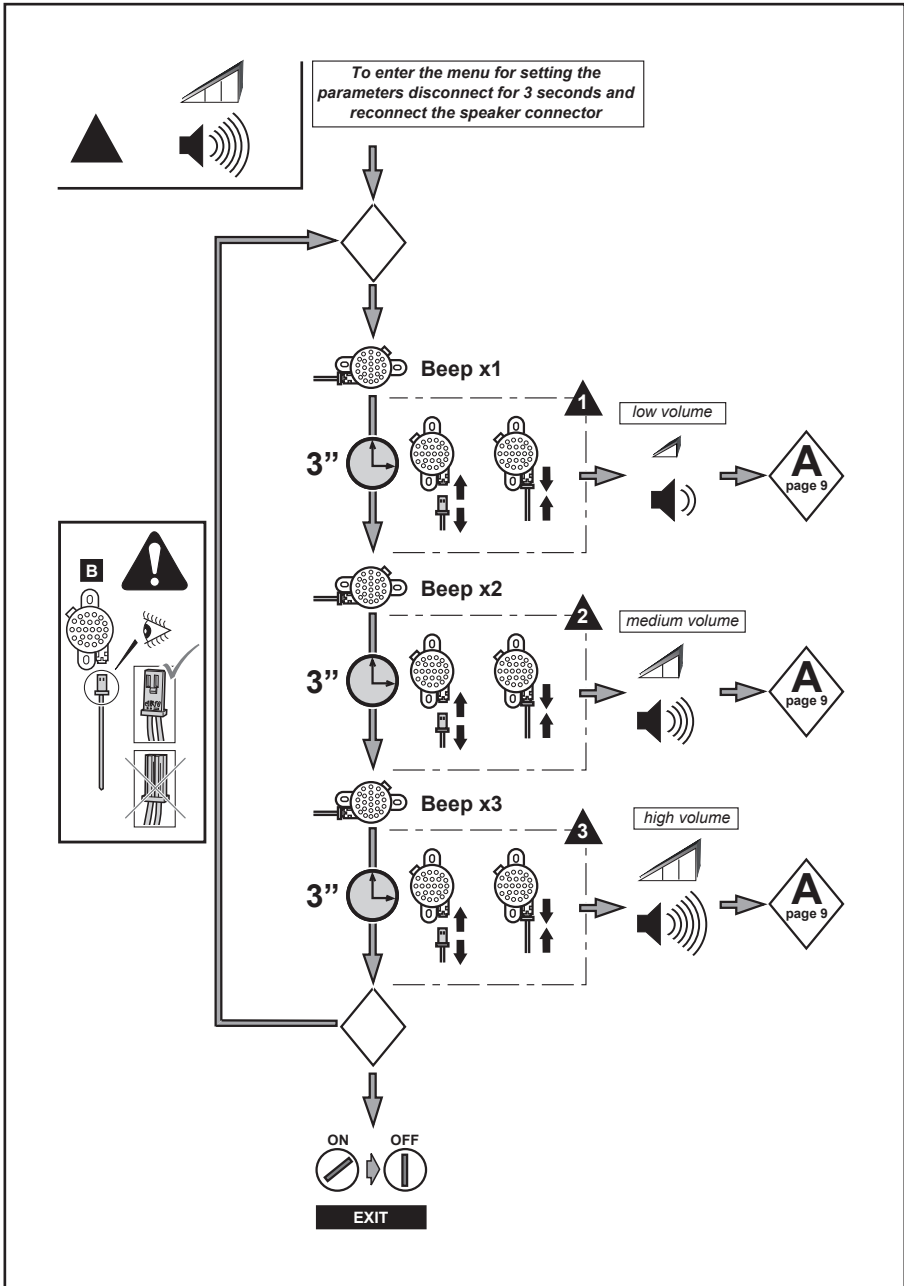

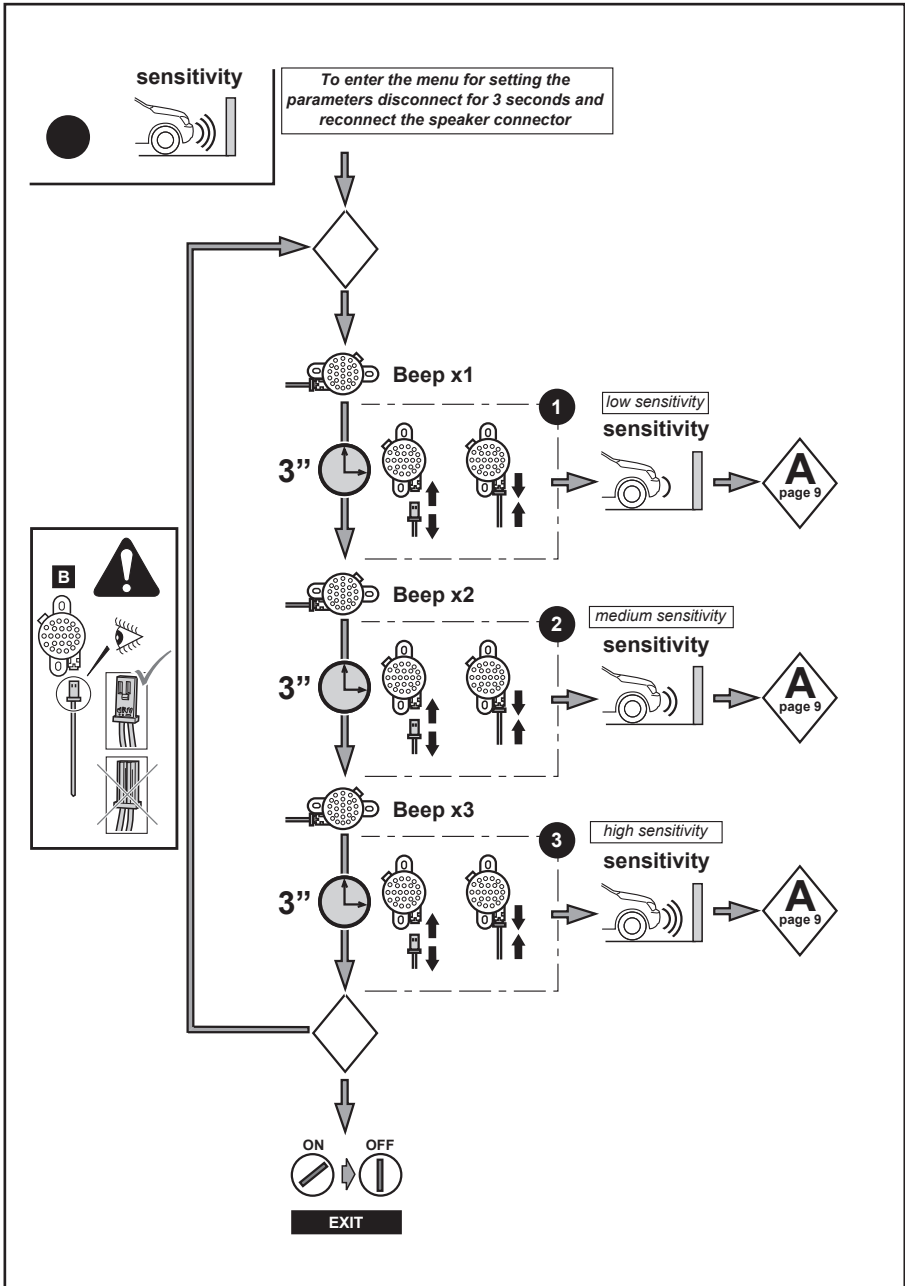

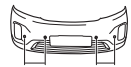

To enter the menu for setting the parameters disconnect for 3 seconds and reconnect the speaker connector

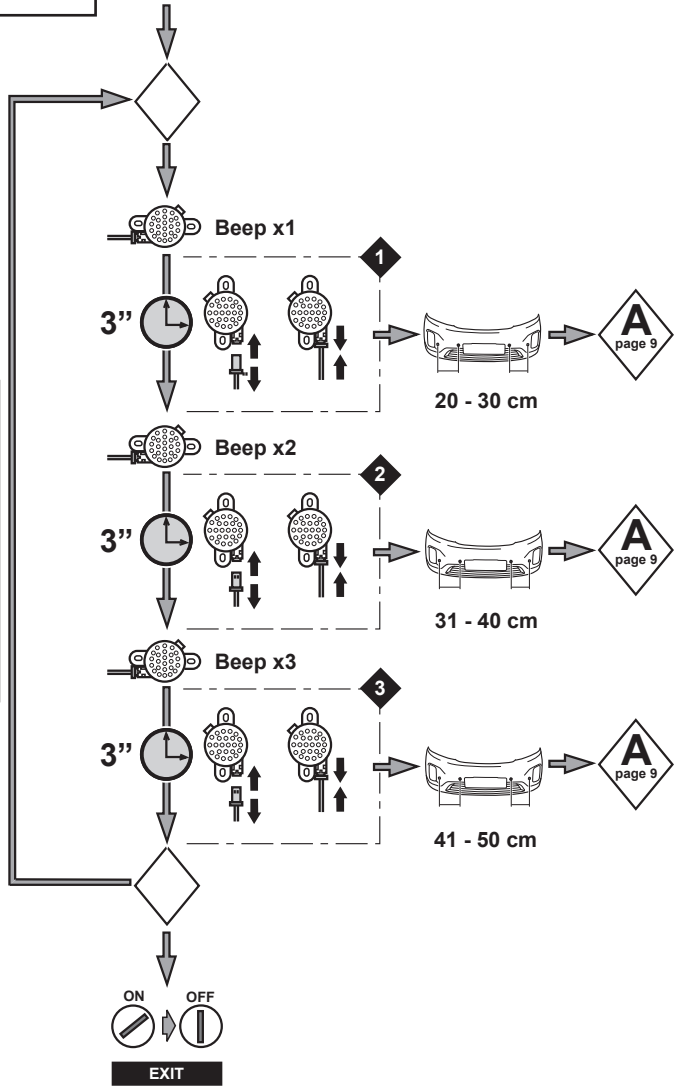
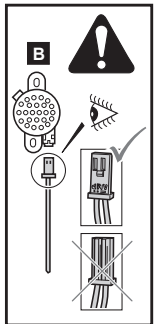

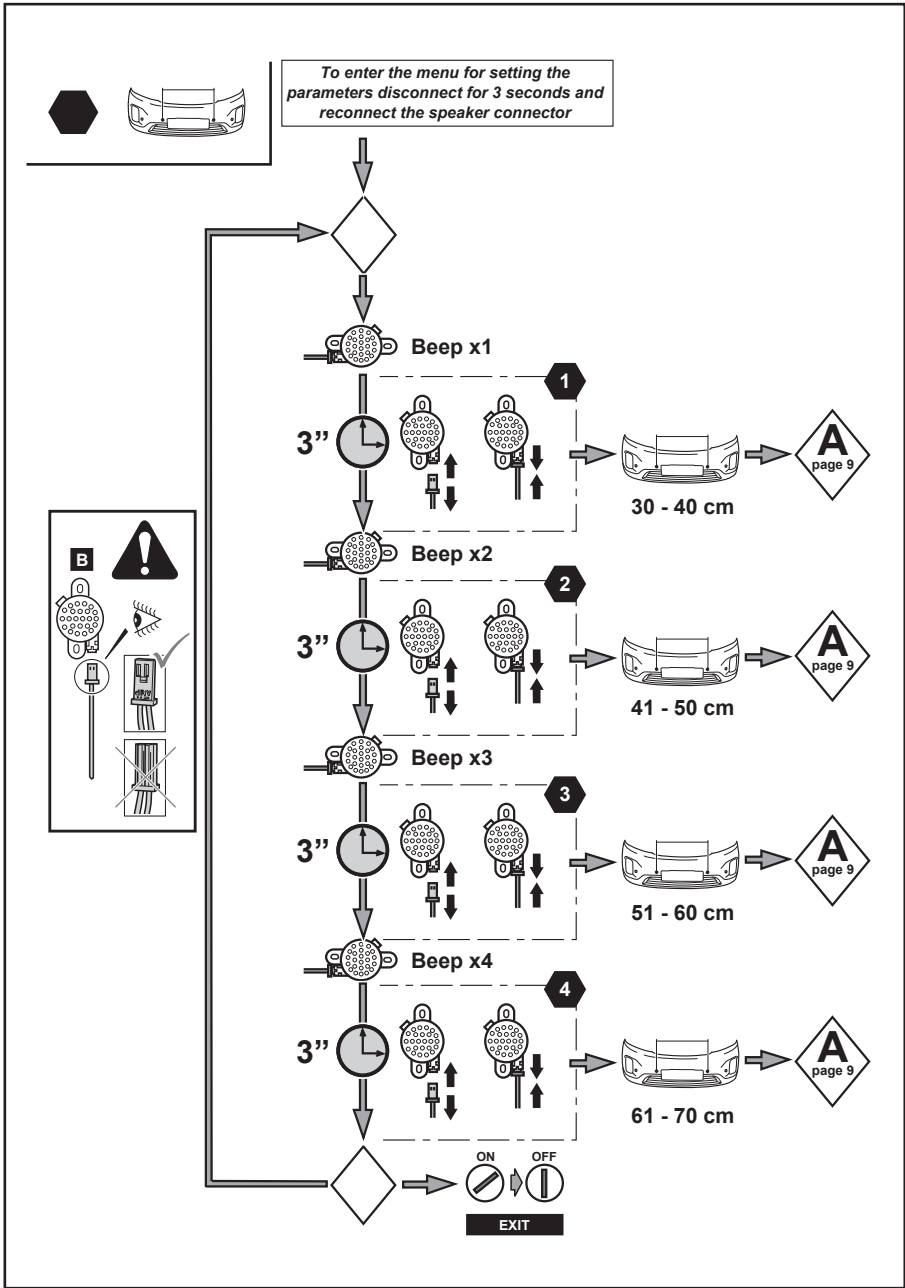





cee'd 5dr + wagon 2012	
cee'd GT 5dr 2013 -----	Pag. 17
pro_cee'd + cee'd GT 3dr 2013 -----	Pag. 39
SORENTO 2012 -----	Pag. 63
CARENS 2013 -----	Pag. 77



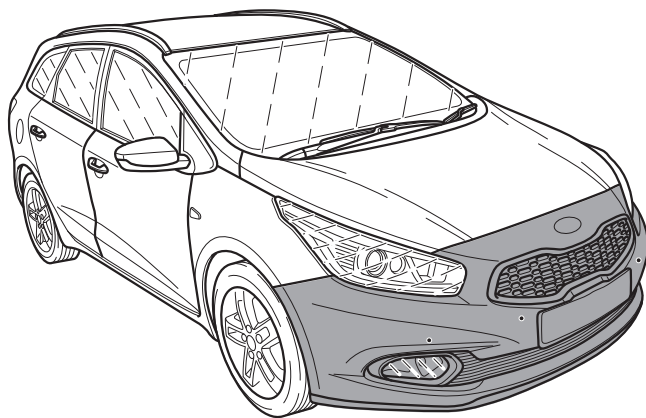

K0080

cee'd 5dr + wagon 2012
cee'd GT 5dr 2013

1

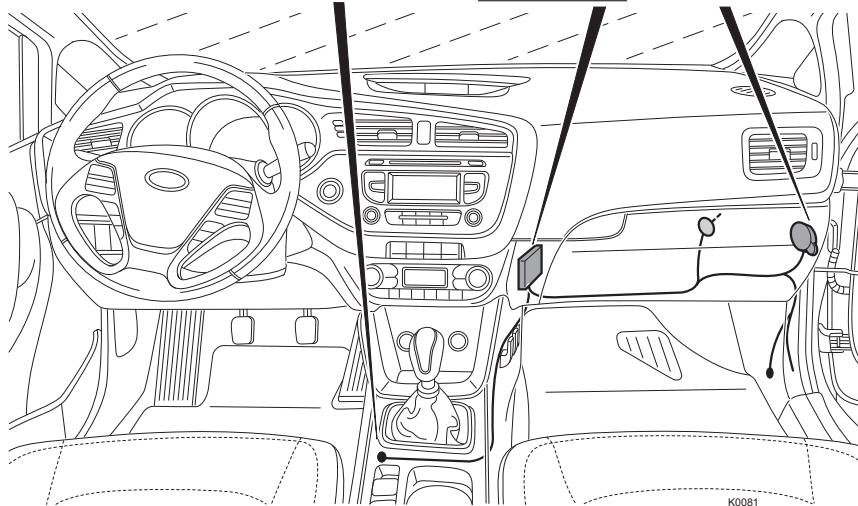
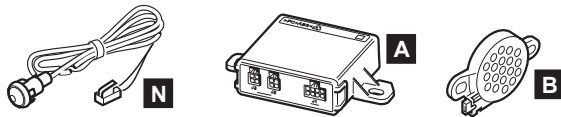

2

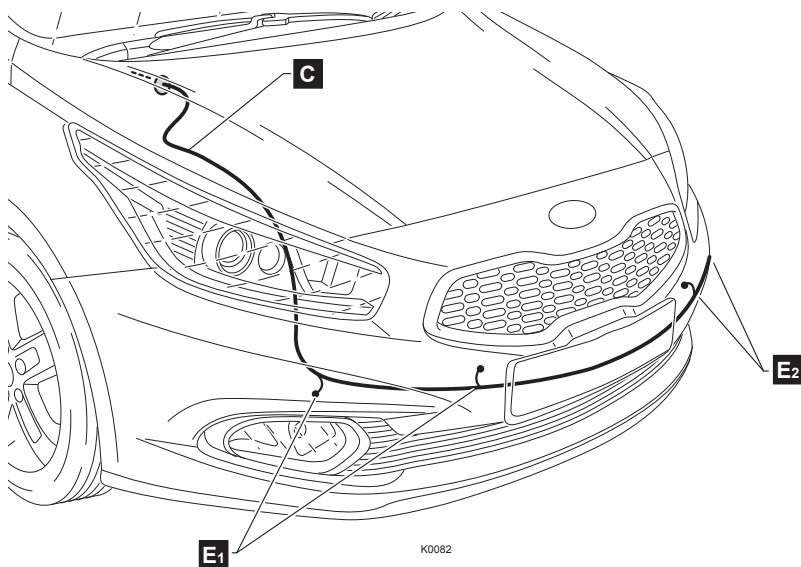

3

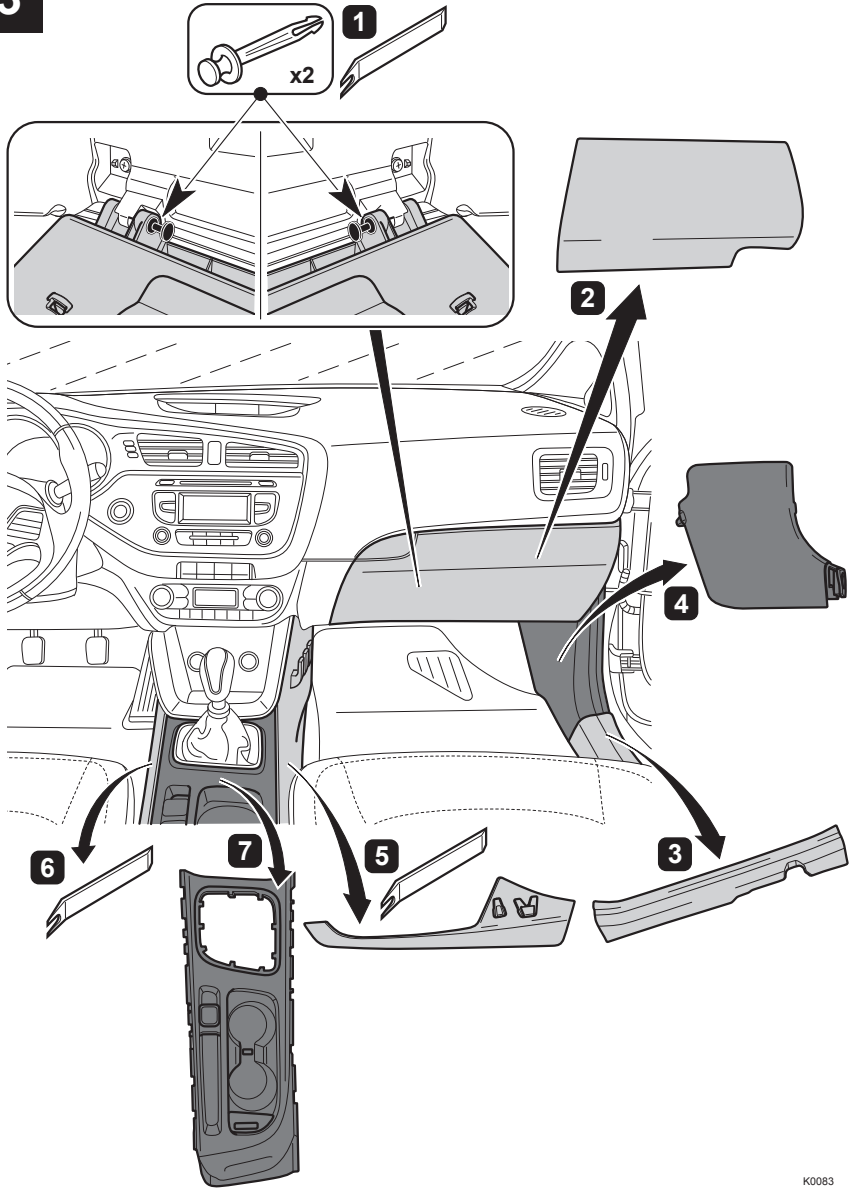

K0083

4

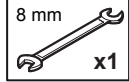
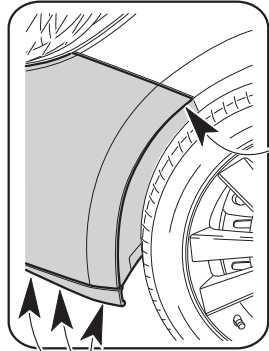
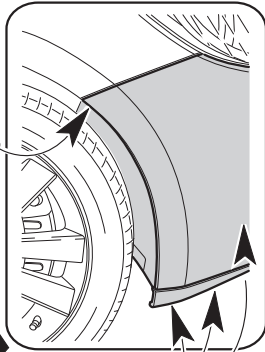
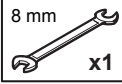

2

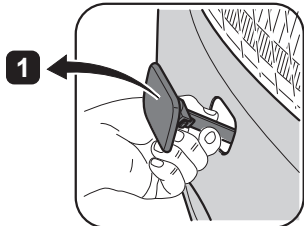
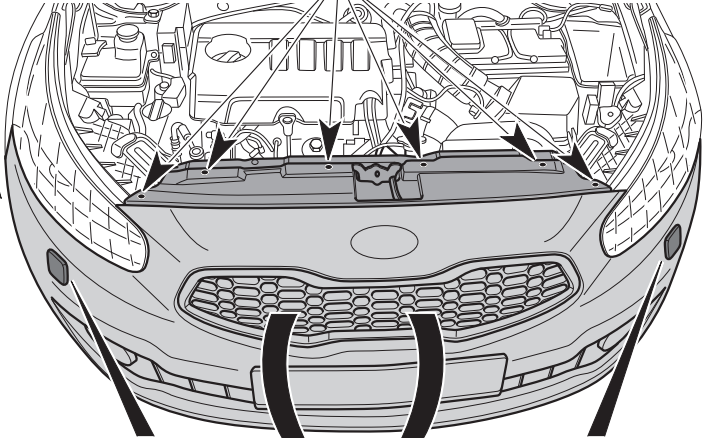

5

5

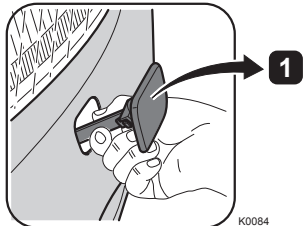

1

K0084

5 cee'd 5dr + wagon 2012

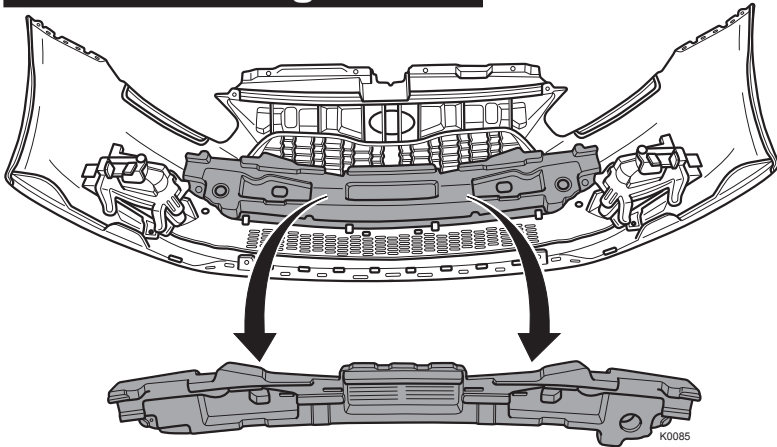

6 cee'd 5dr + wagon 2012

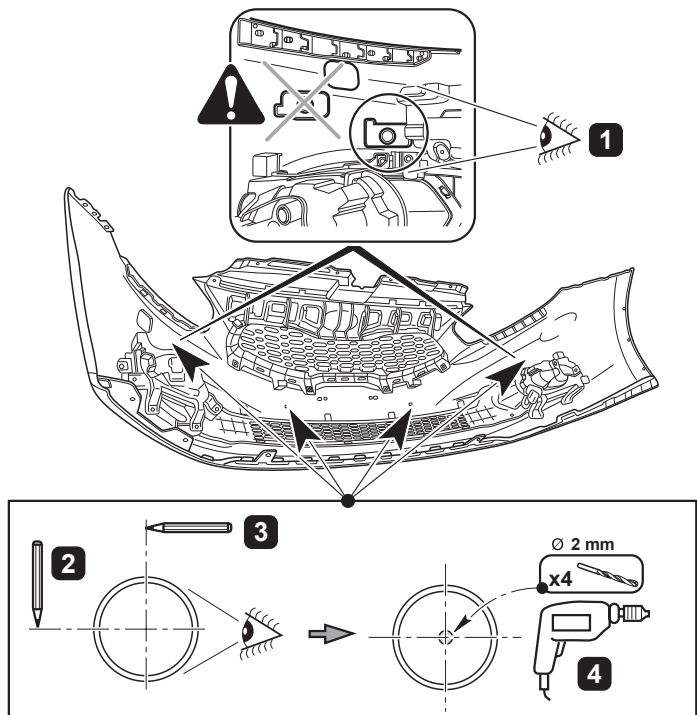

7

cee'd 5dr + wagon 2012

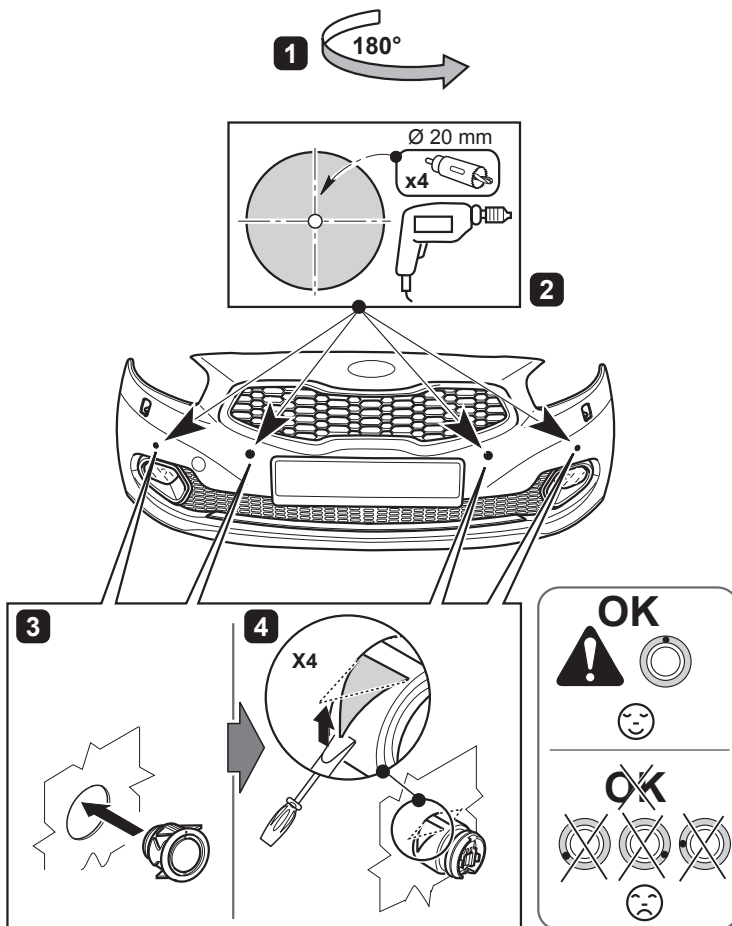

7a cee'd GT 5dr 2013

16 17
18 19

1

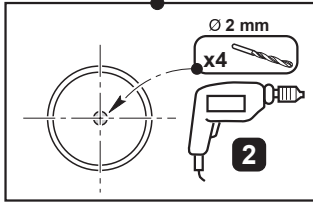
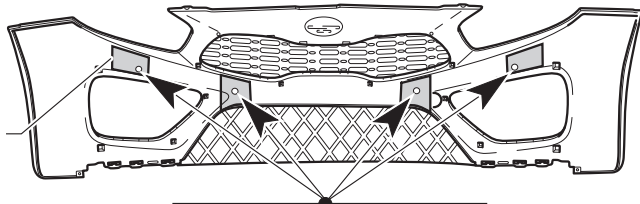

3 180°

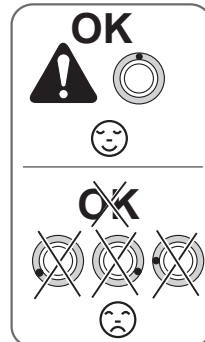
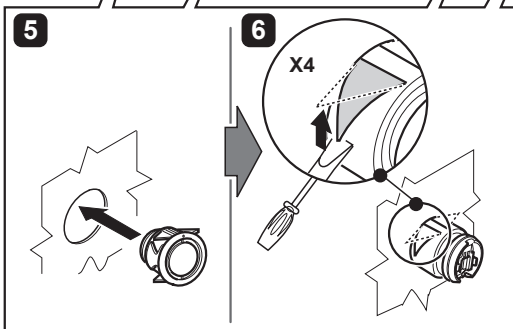
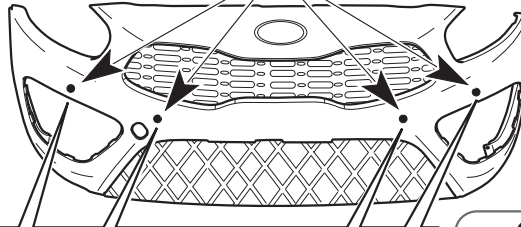
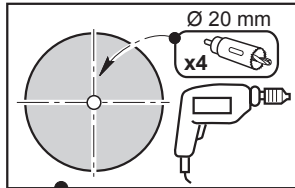

K0164

8

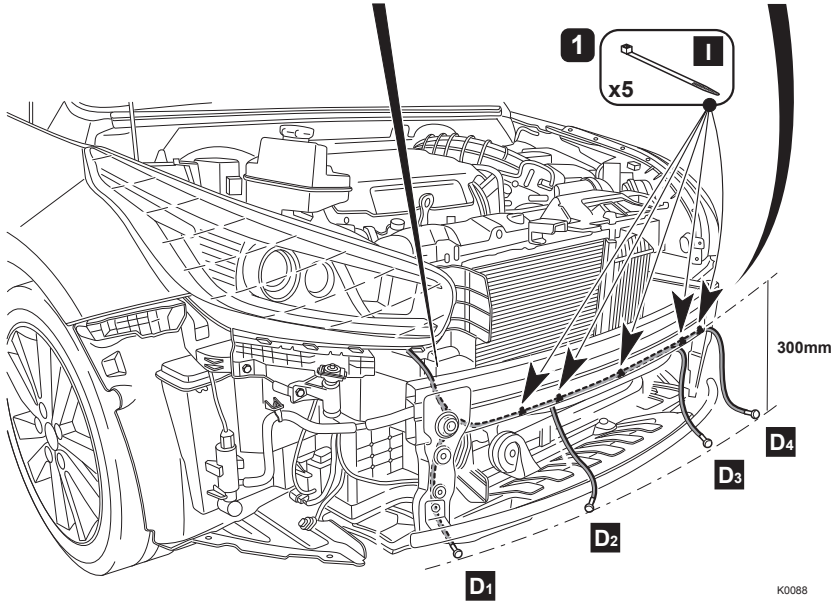
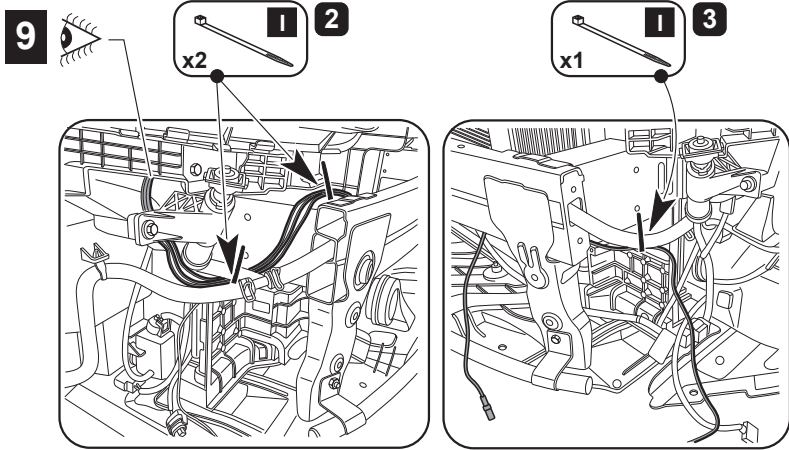

9

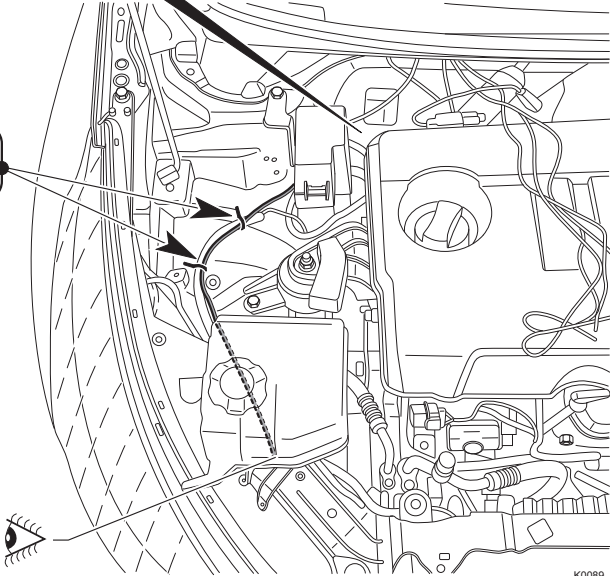
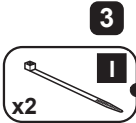
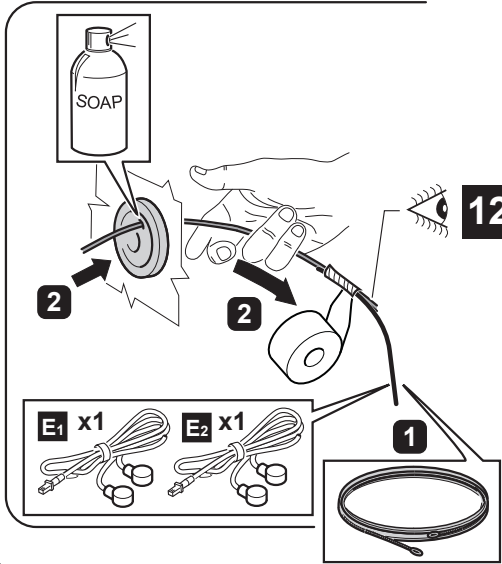
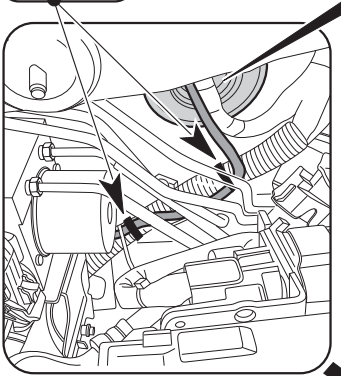

K0089

10

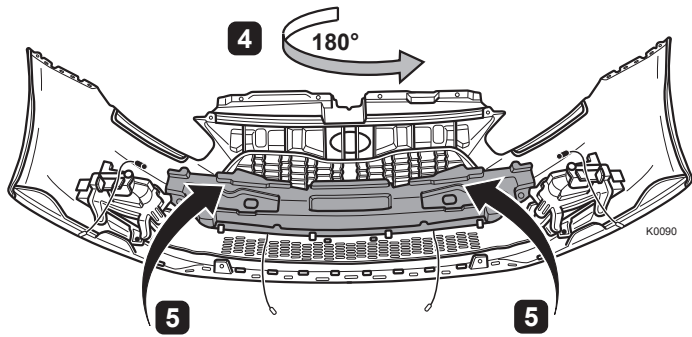
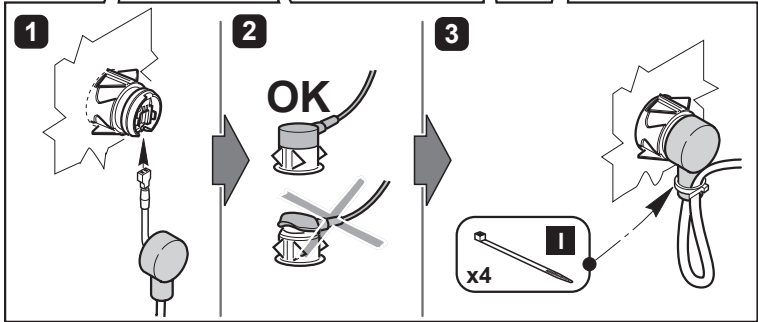
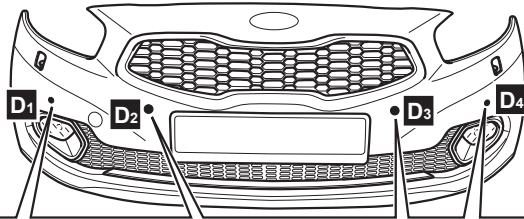

11

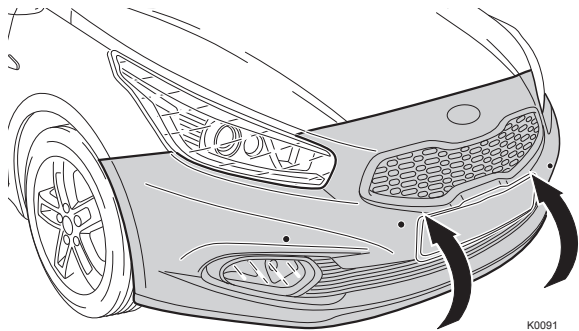

12

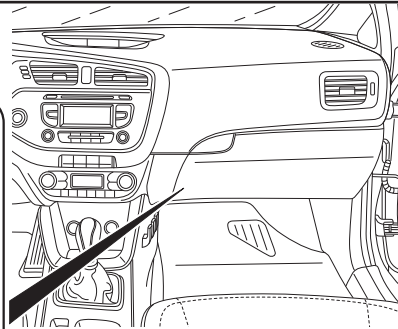
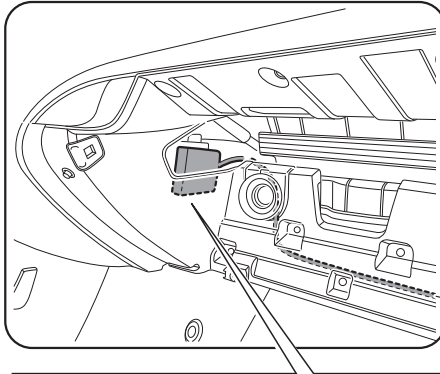

13

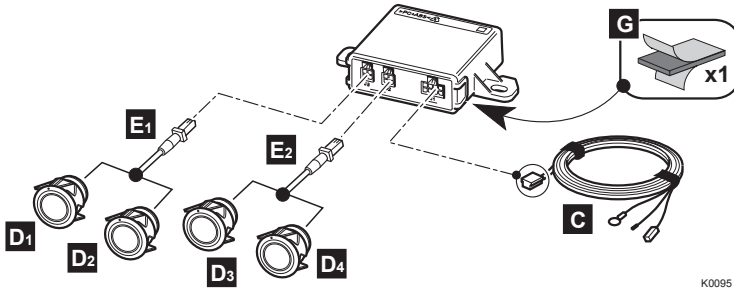

K0095

13

12 15

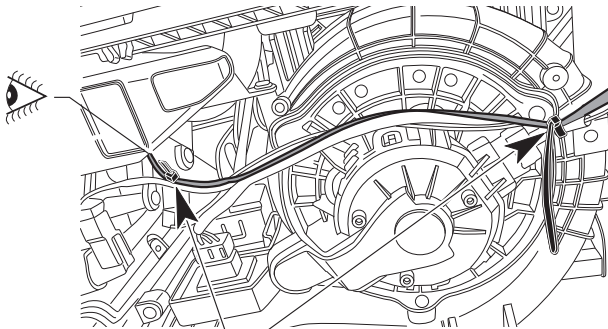

14



K0094

14

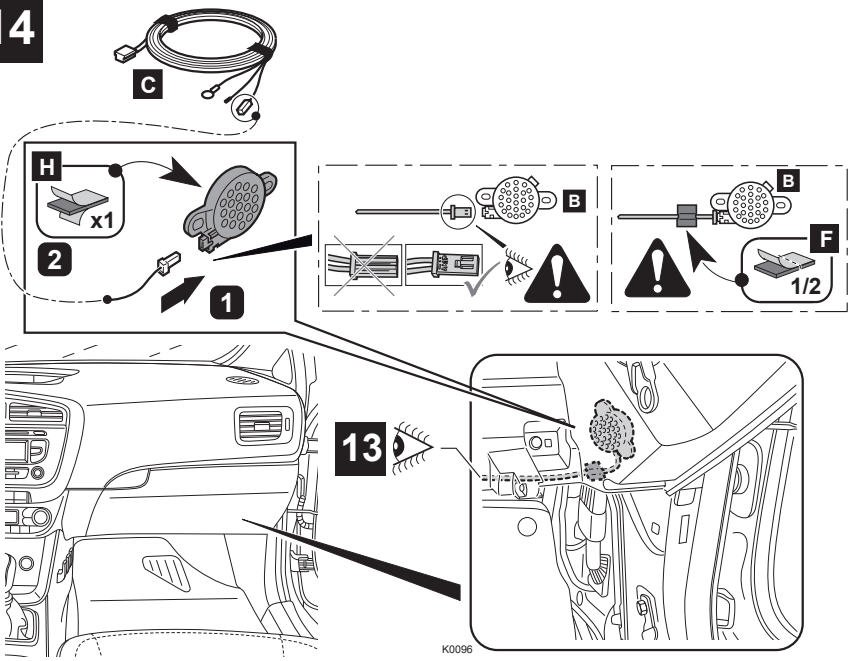

15

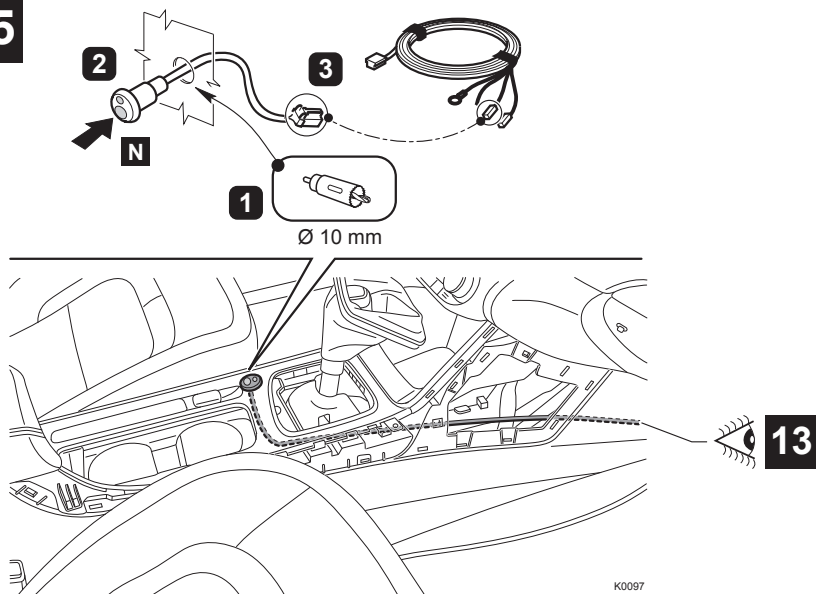

16

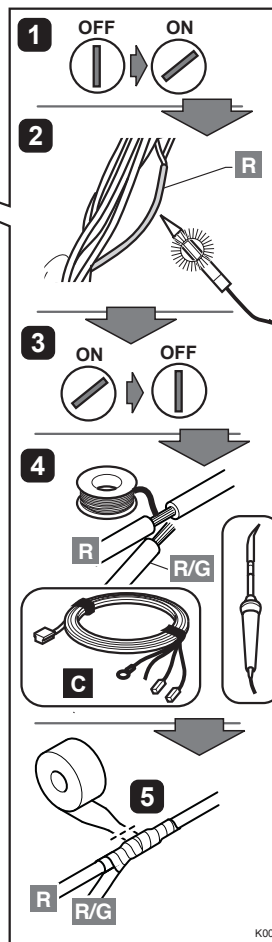
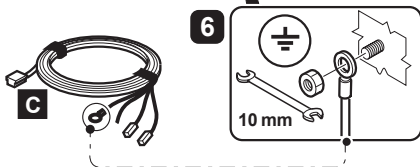
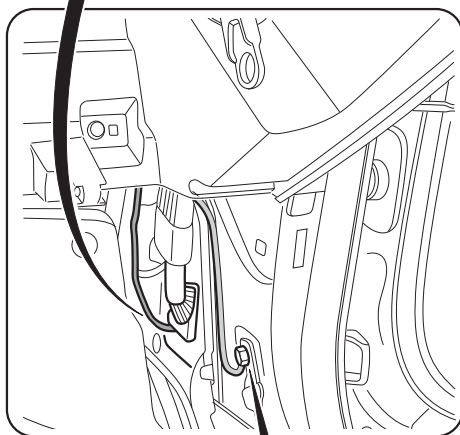
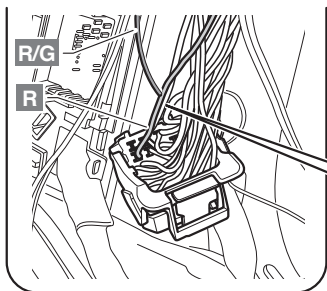

K0093

R	RED	ROT	ROUGE	ROOD	ROD	ROSSO	ROD
VERMELHO	ROJO	ROD	ČERVENÁ	PUNAINEN	CZERWONY	КРАСНЫЙ	ČERVENÝ
G	GREEN	GRÜN	VERT	GROEN	GRØN	VERDE	GRØNN
VERDE	VERDE	GRÜN	ZELENÁ	VIHREÄ	ZIELONA	ЗІЛНИЙ	ZELENÝ

15

SETUP

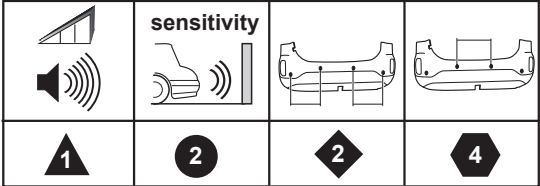

K0098

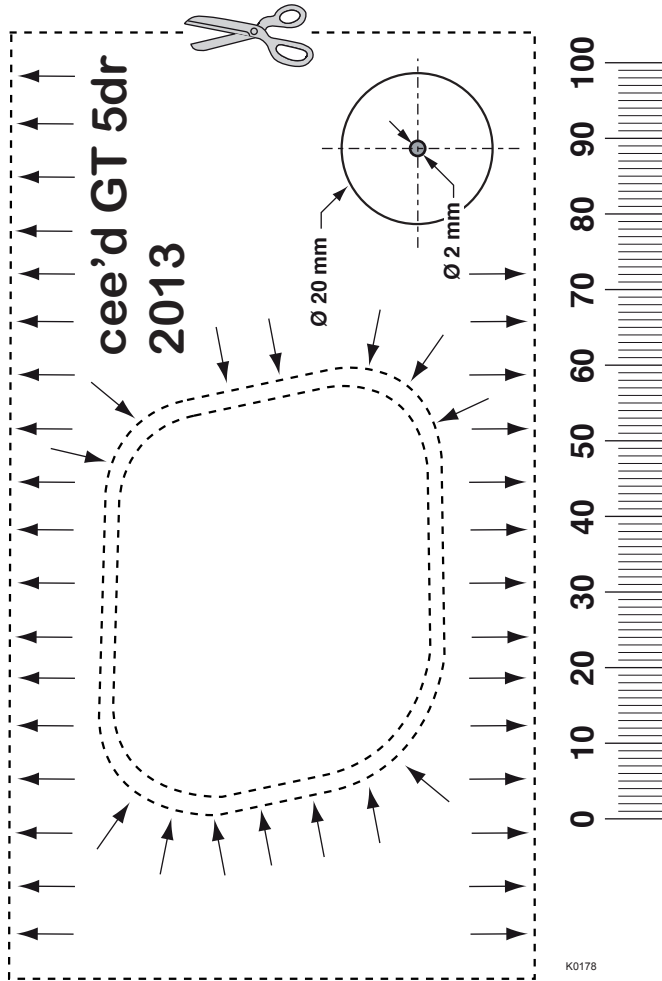
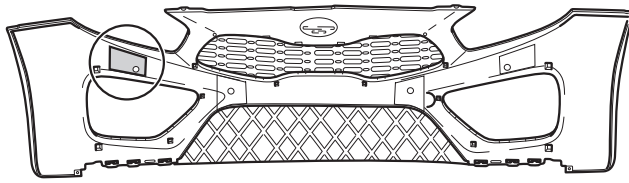

K0178



17

cee'd GT 5dr 2013

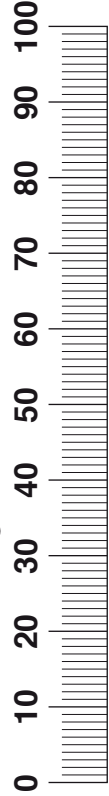
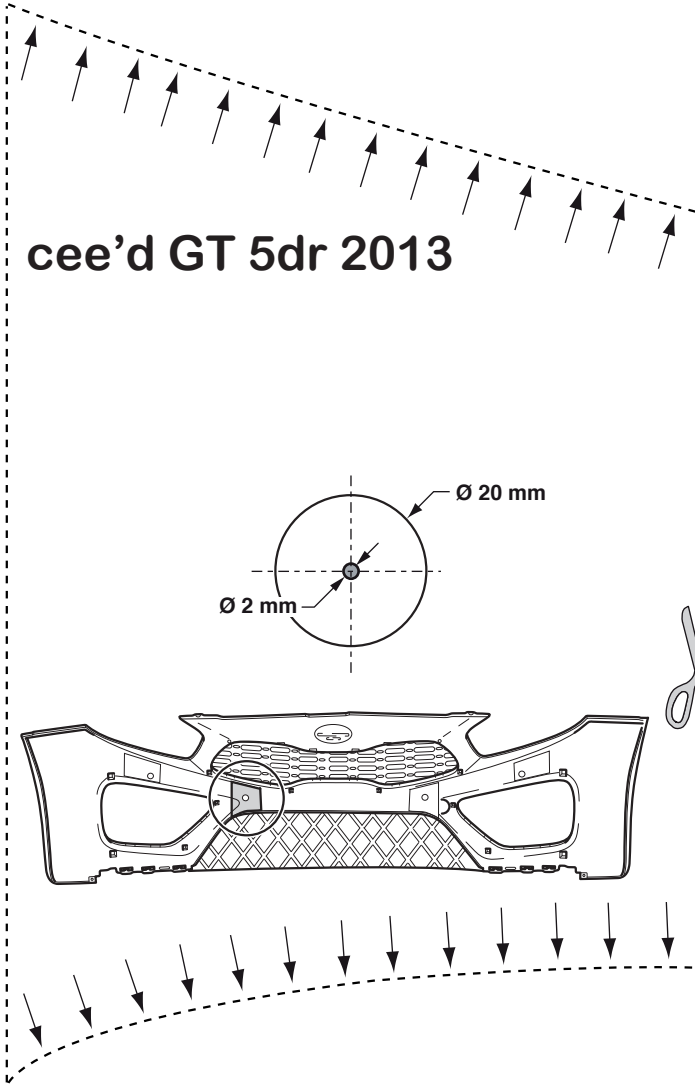

K0178



18

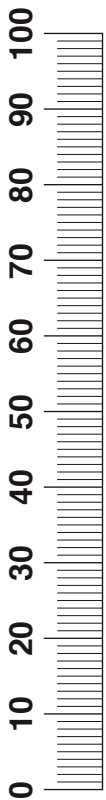

cee'd GT 5dr 2013

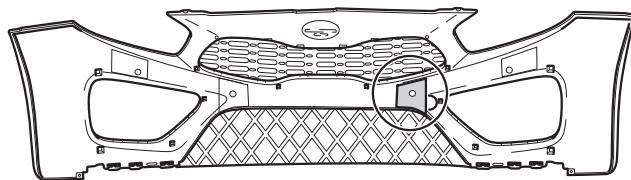
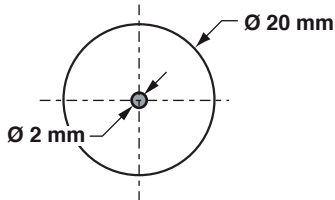

K0178



19

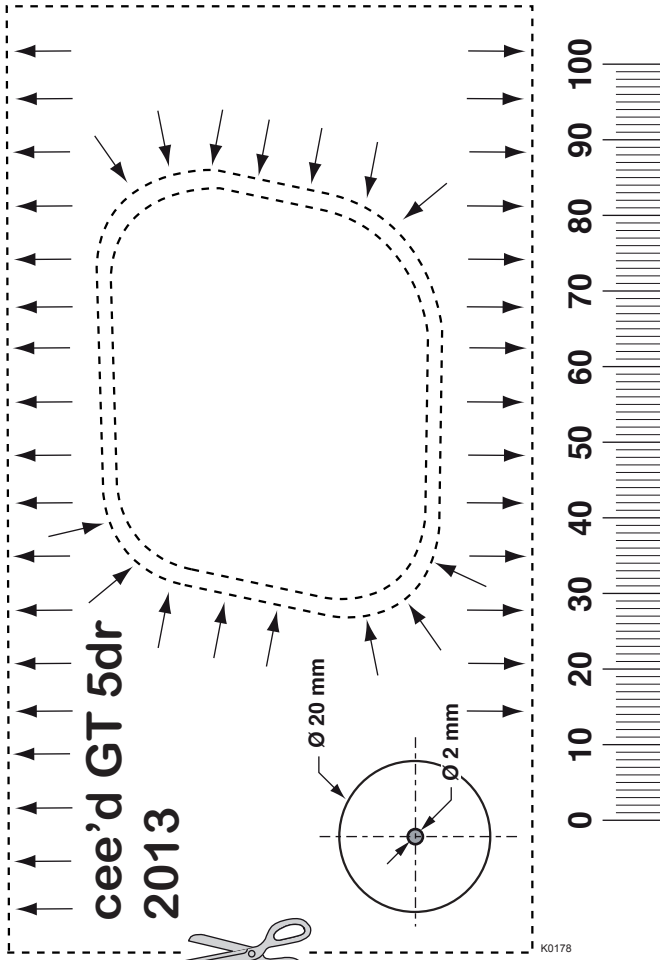
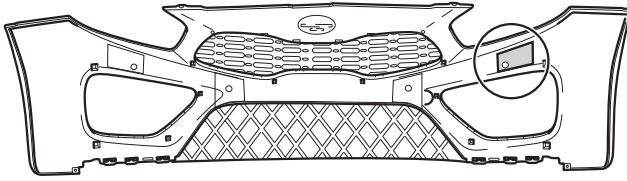



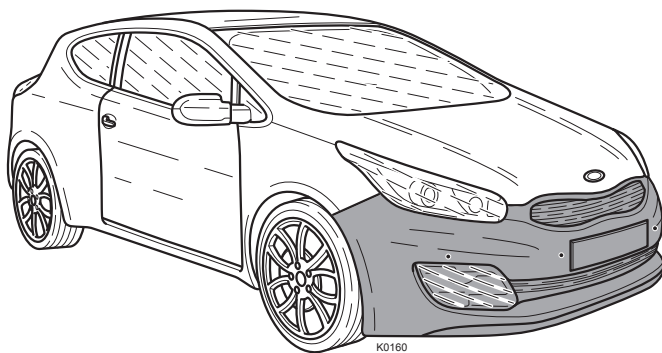

**pro_cee'd +
cee'd GT 3dr 2013**

1

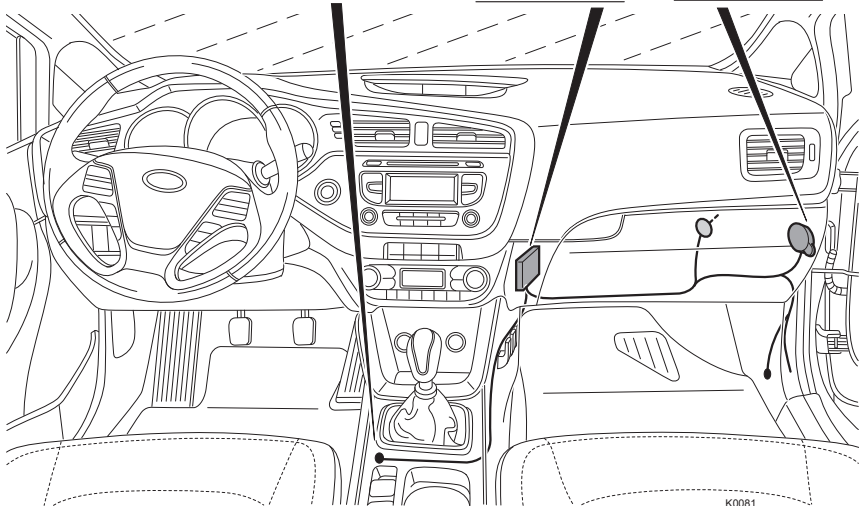

K0081

2

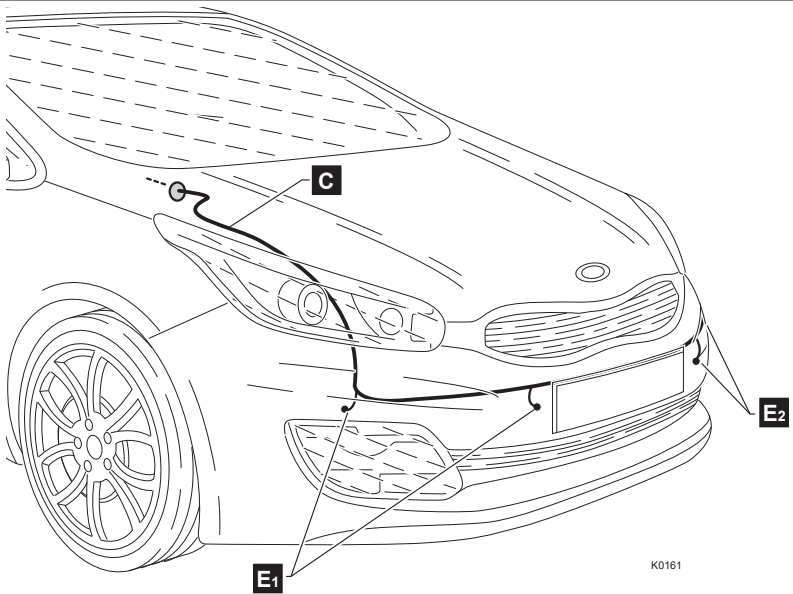

K0161

3

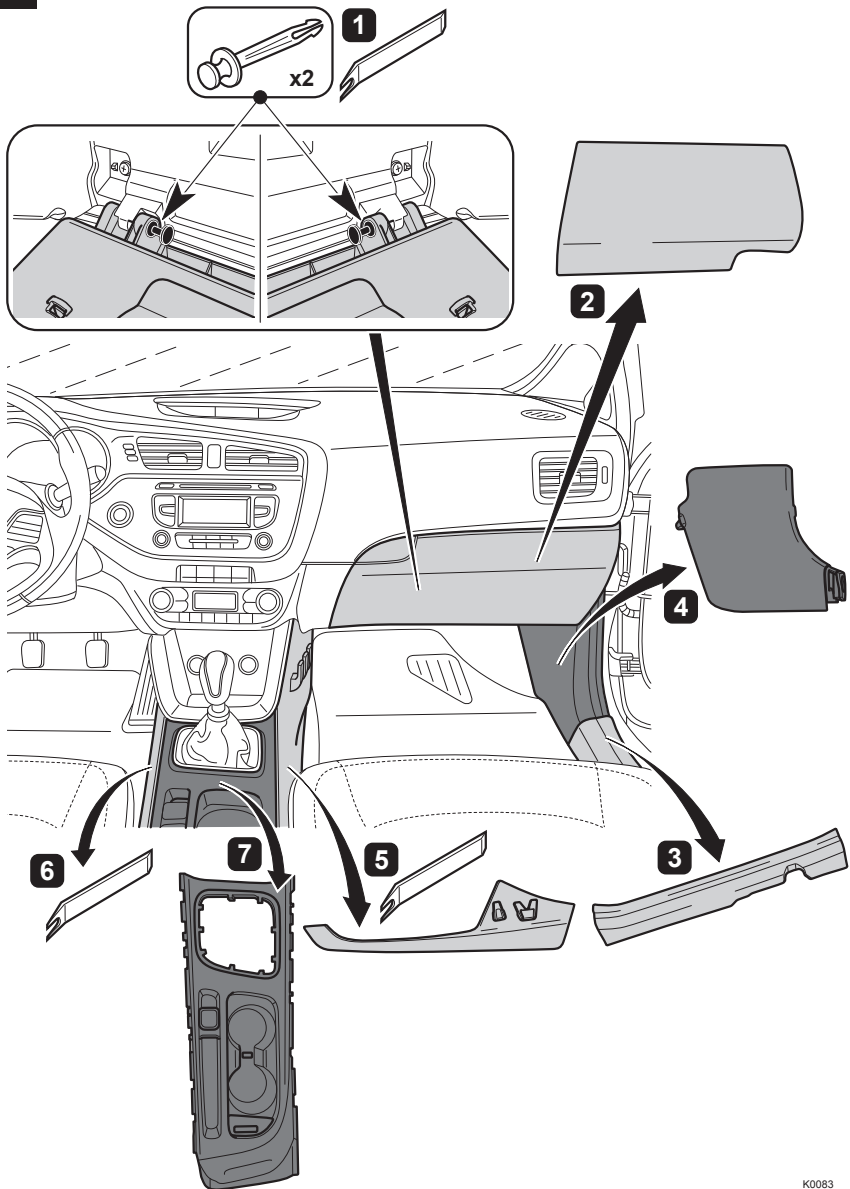

K0083

4

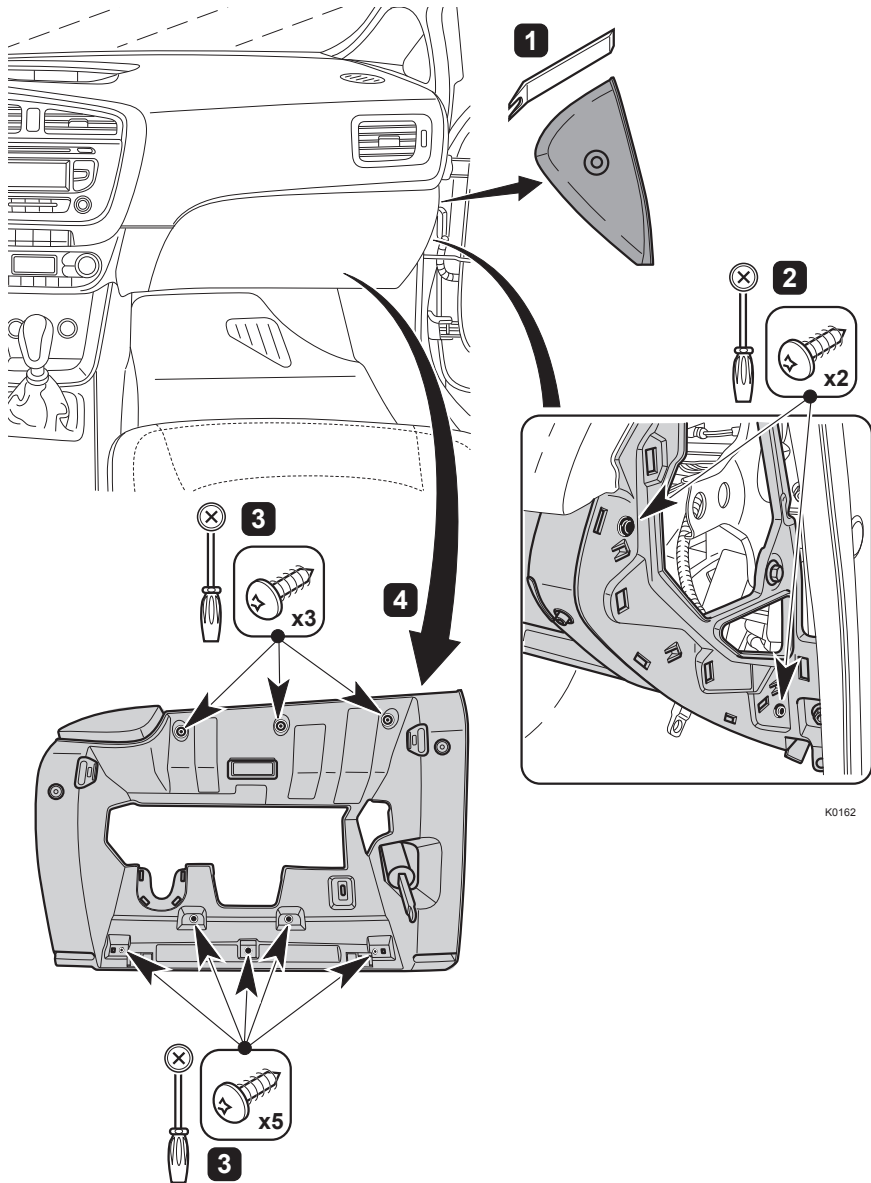

5

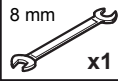

4

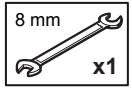
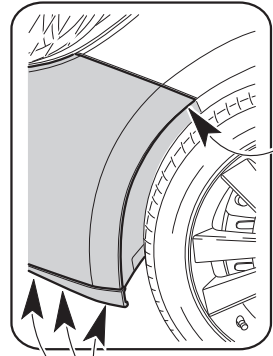
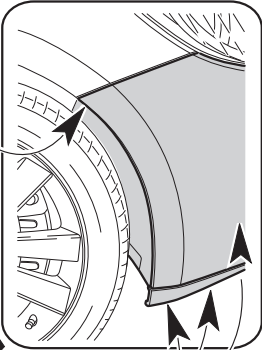

4



2



3

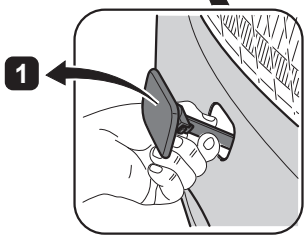
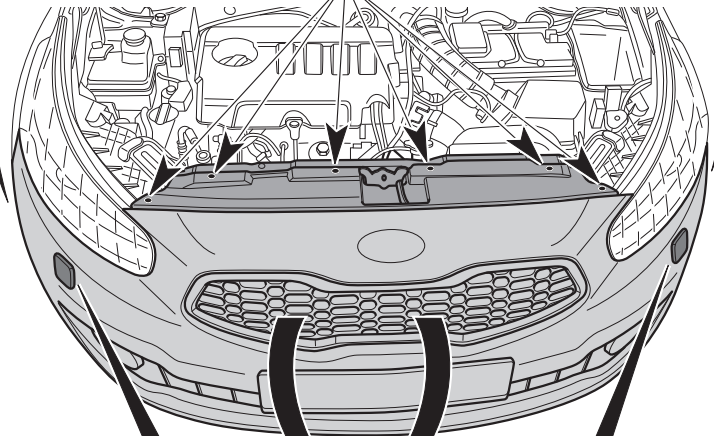

5

5

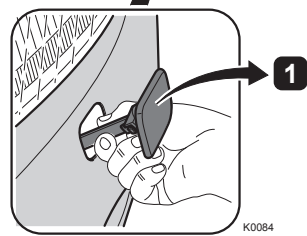

K0084

6 pro_cee'd 2013

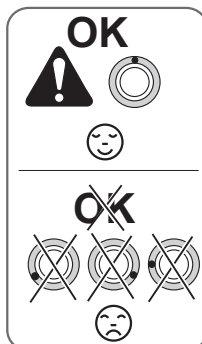
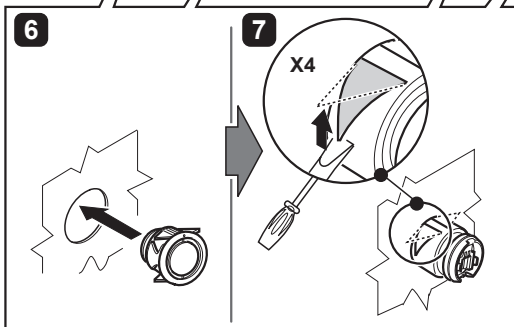
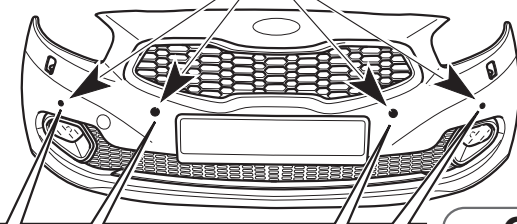
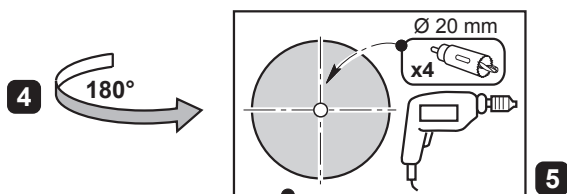
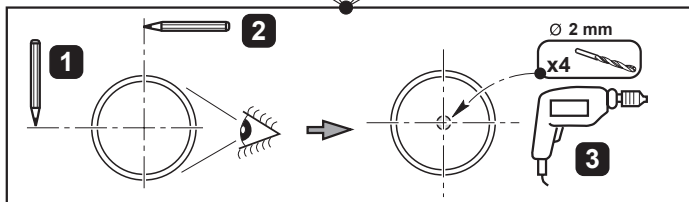
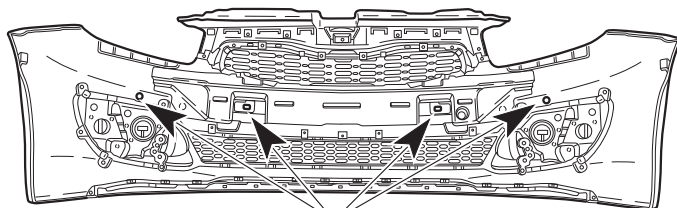

R0163

6a pro_cee'd GT 3dr 2013

18 19
20 21

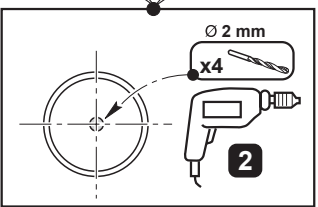
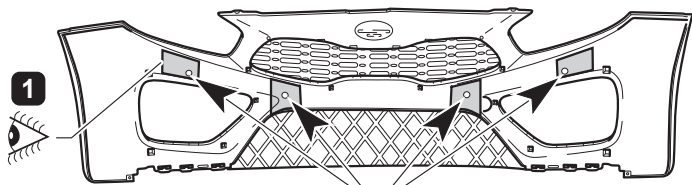

3 180°

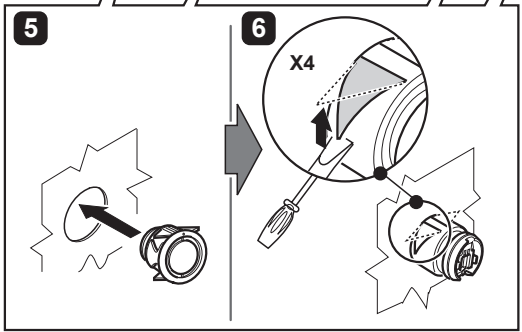
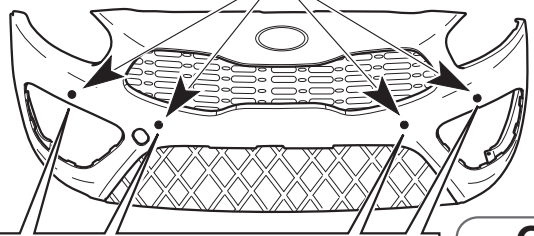
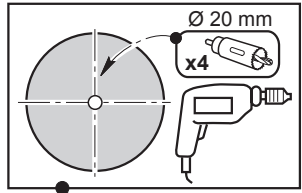

OK

OK

K0164

7

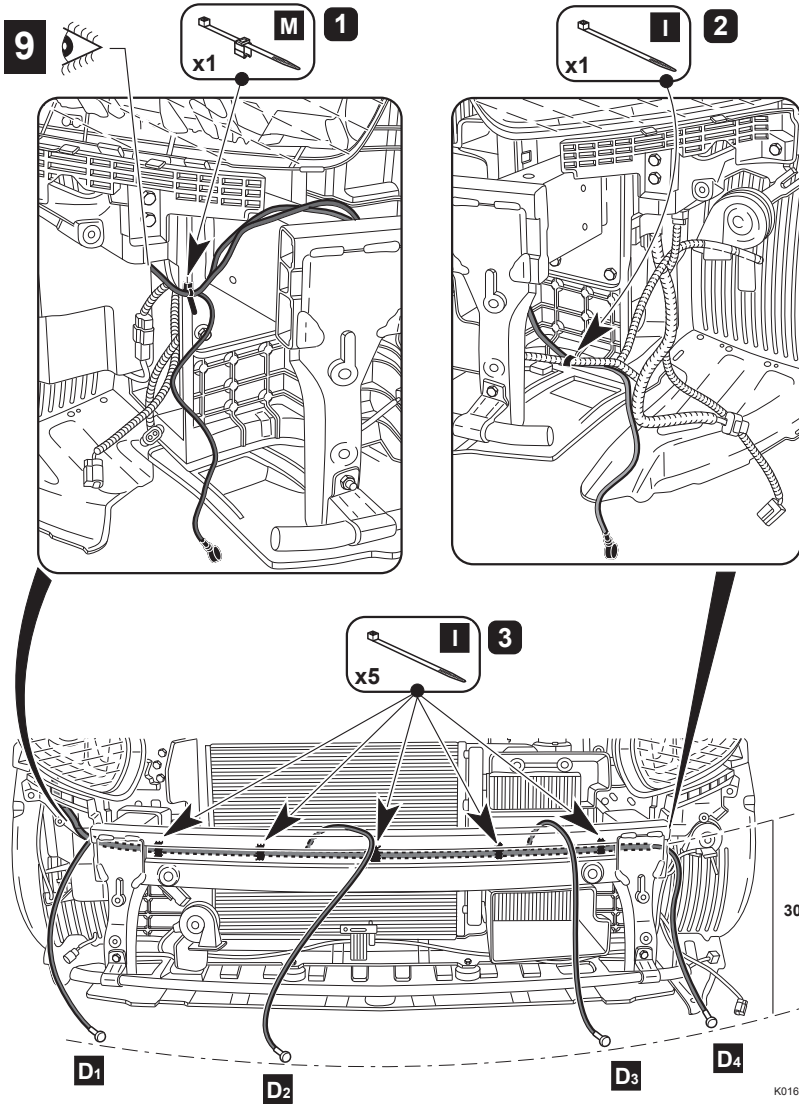

K0165

8

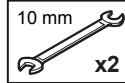
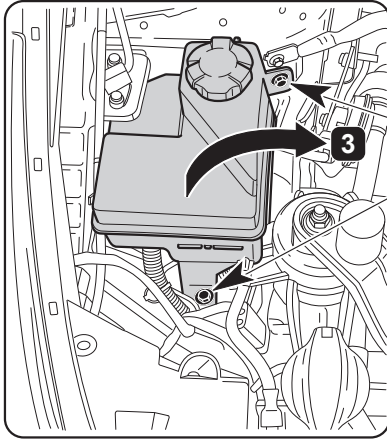

1

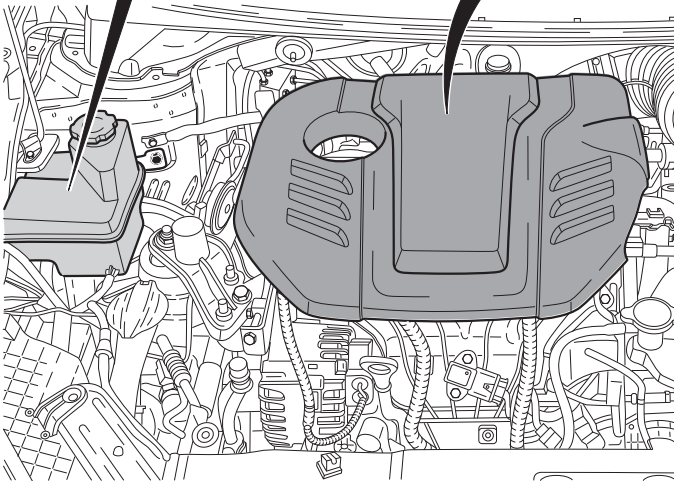
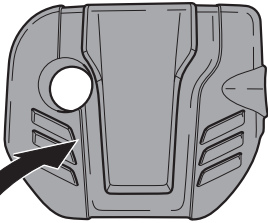

K0166

9

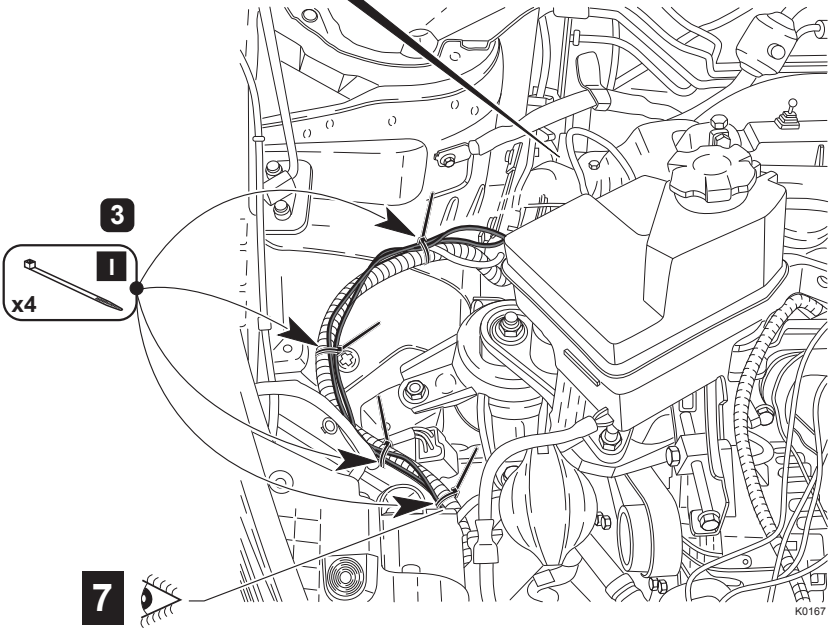
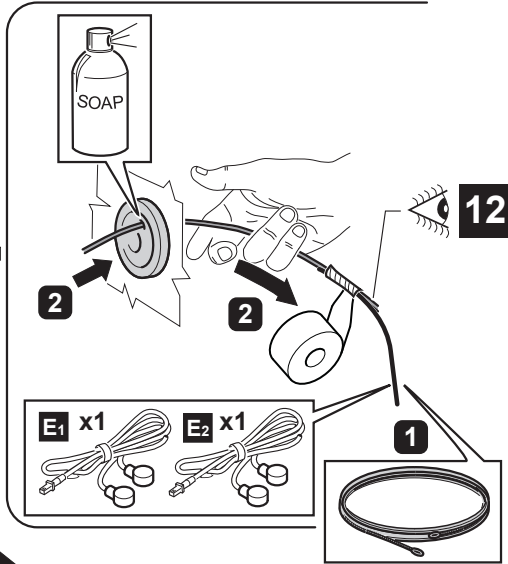
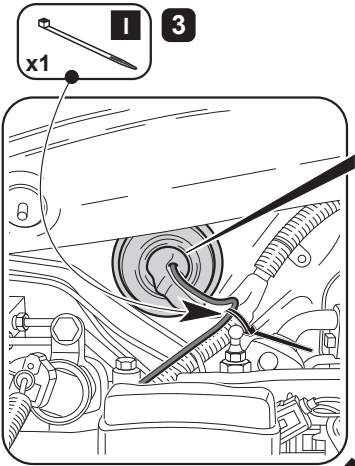

K0167

10

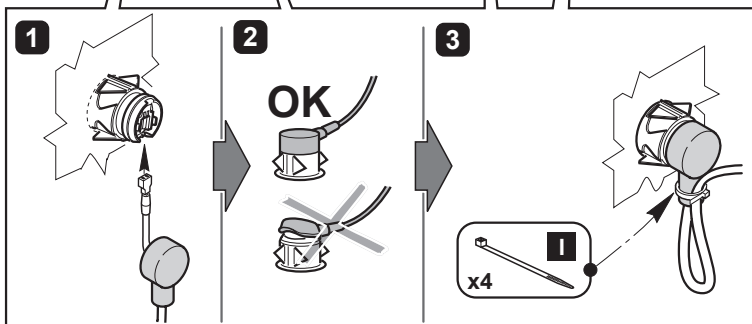
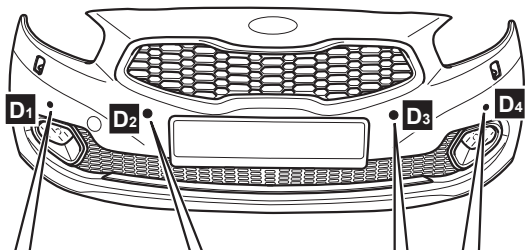

K0168

11

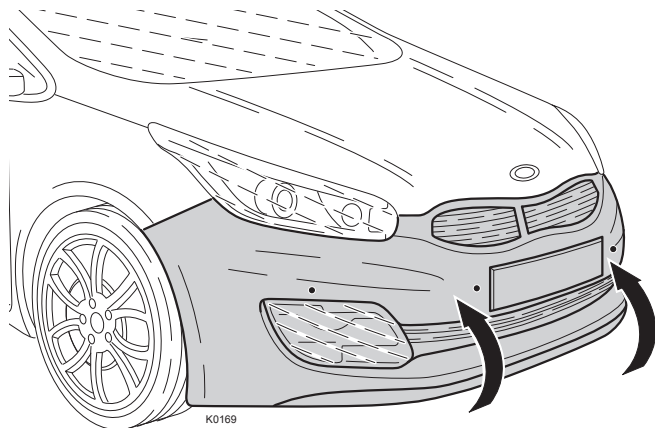

K0169

12

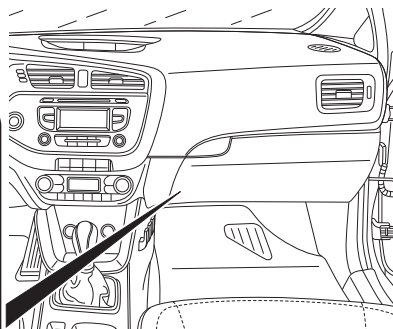
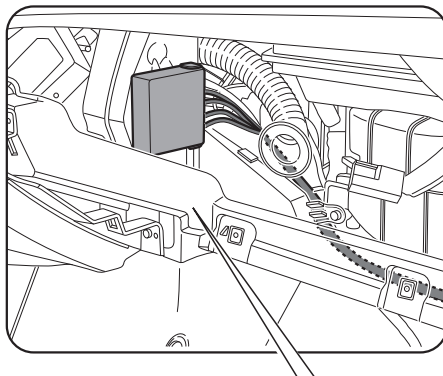

13

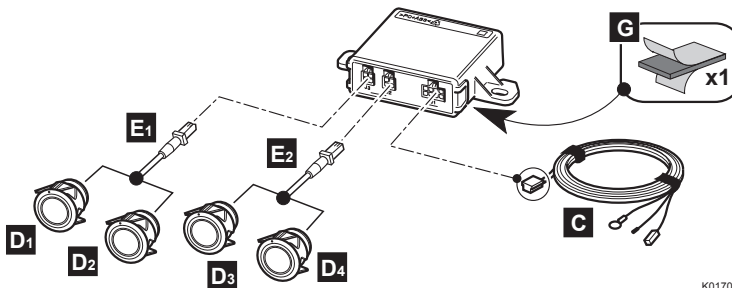

K0170

13

12 15

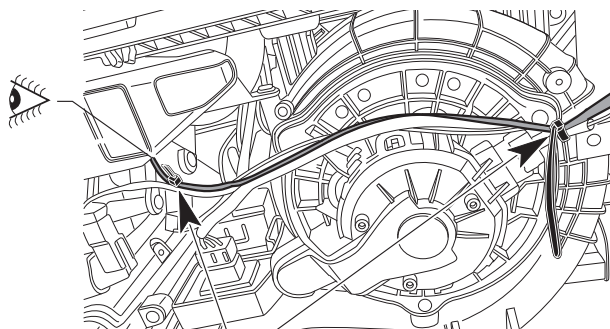

14

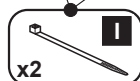

K0094

14

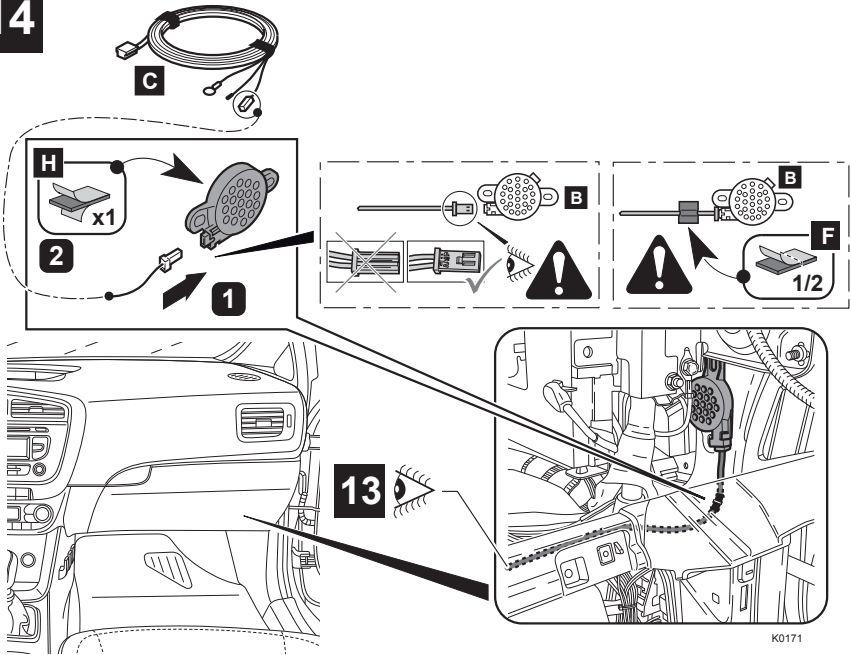

15

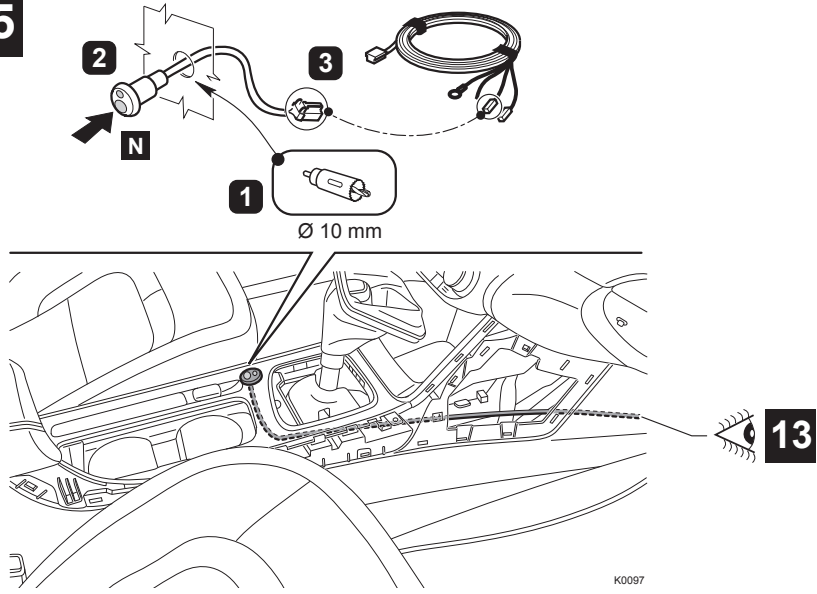

16

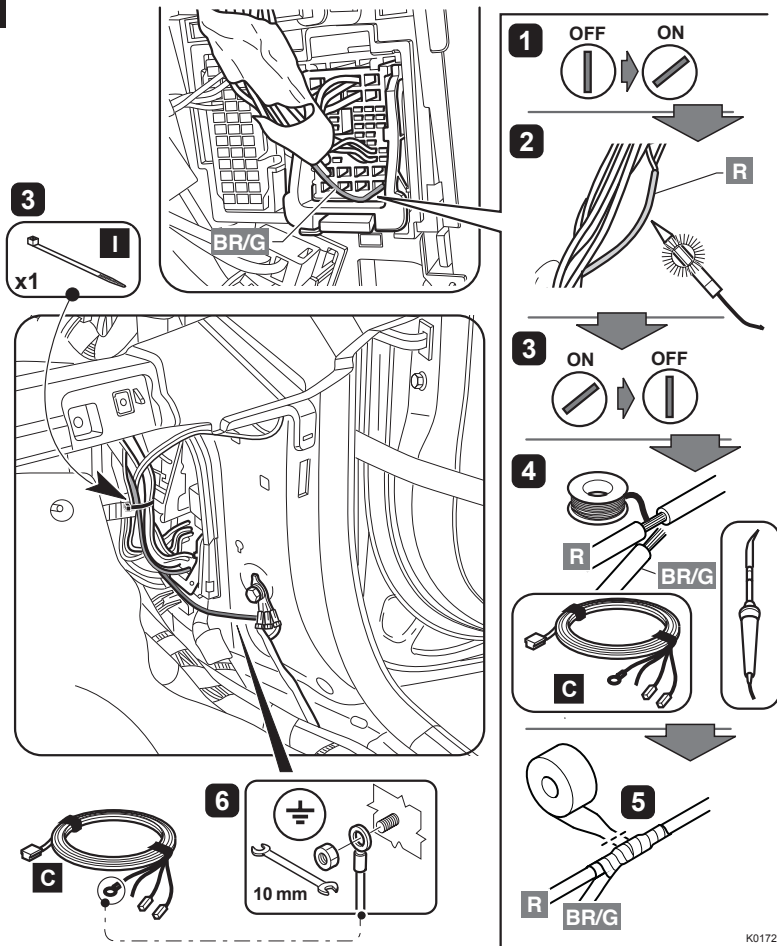

K0172

R	RED	ROT	ROUGE	ROOD	ROD	ROSSO	ROD
VERMELHO	ROJO	ROD	ČERVENÁ	PUNAINEN	CZERWONY	КРАСНЫЙ	ČERVENÝ
G	GREEN	GRÜN	VERT	GROEN	GRÖN	VERDE	GRÖNN
VERDE	VERDE	GRÖN	ZELENÁ	VIHREÄ	ZIELONA	ЗЕЛЕНАЯ	ZELENÁ
BR	BROWN	BRAUN	MARRON	BRUIN	BRUN	MARRONE	BRUN
CASTANHO	MARRÓN	BRUN	HNĚDÝ	RUSKEA	BRAZOWA	БРАУН	HNEDÁ

17

SETUP

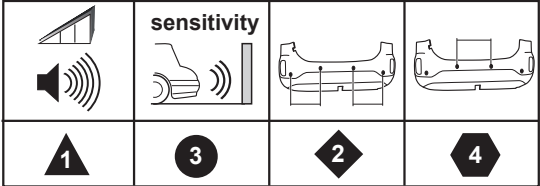

K0175



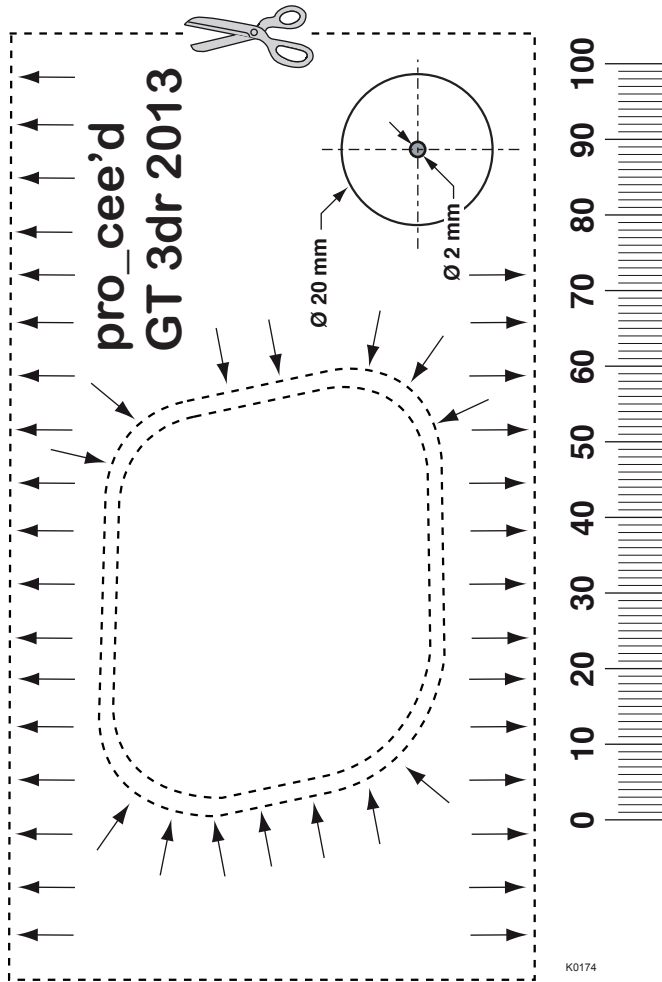
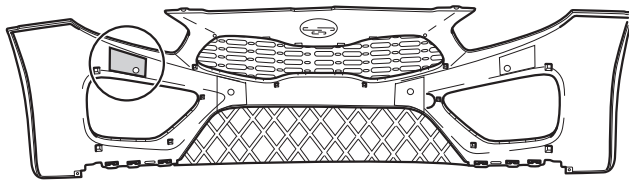

K0174



19

pro_ceed GT 3dr
2013

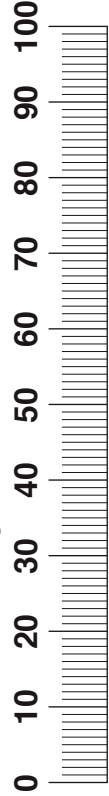
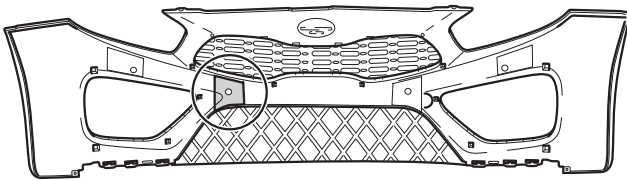
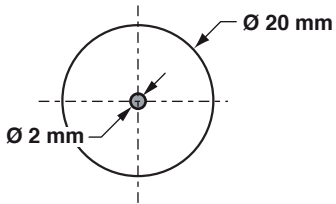

K0174





pro_ceed GT 3dr 2013

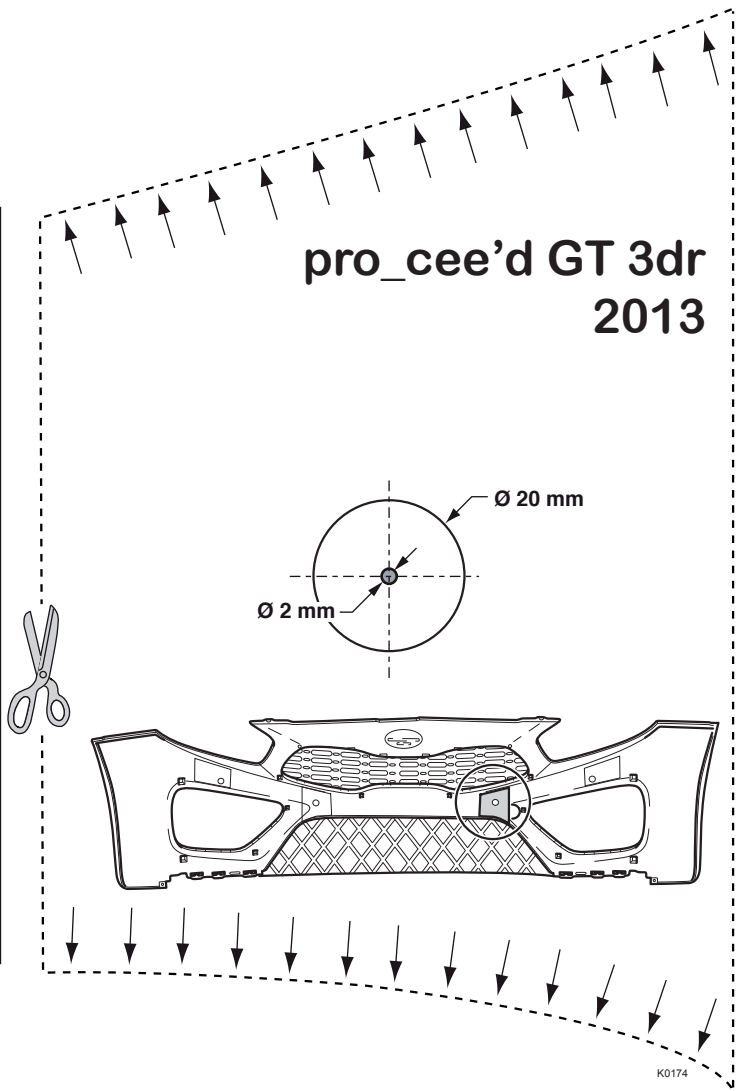
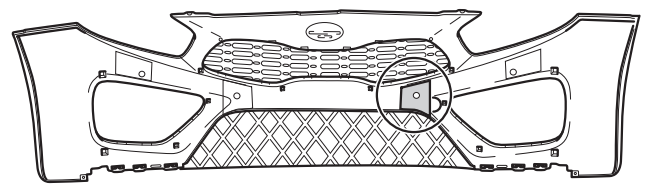
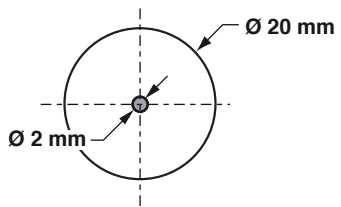

K0174



21

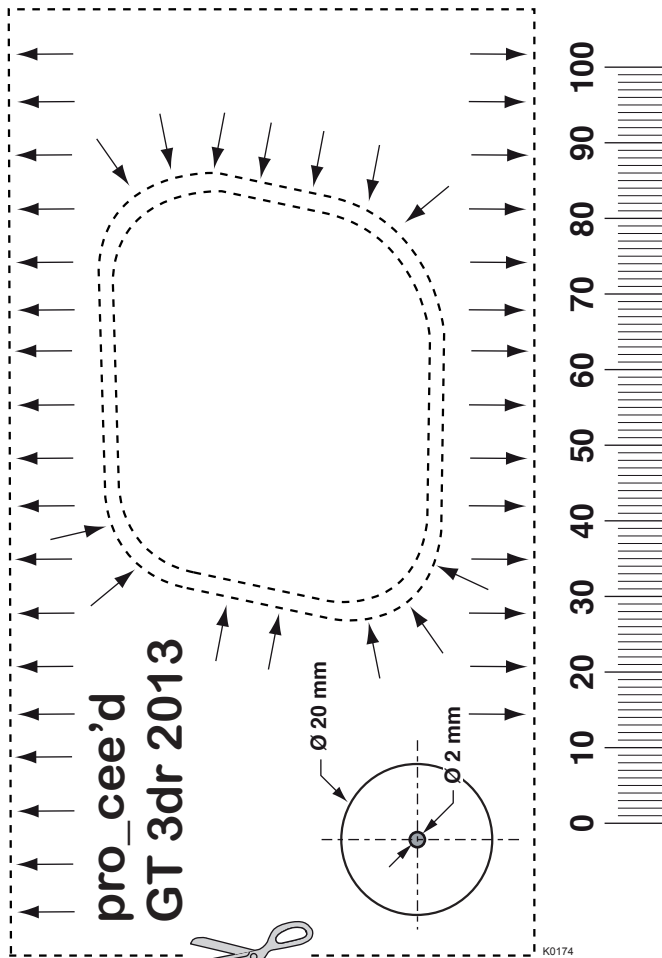
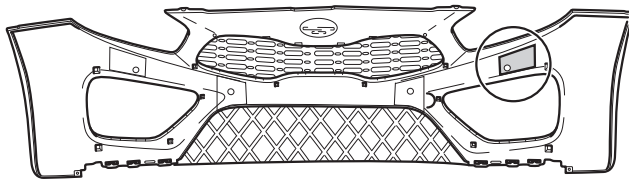

pro_ceed
GT 3dr 2013

Ø 20 mm

Ø 2 mm

0 10 20 30 40 50 60 70 80 90 100

K0174



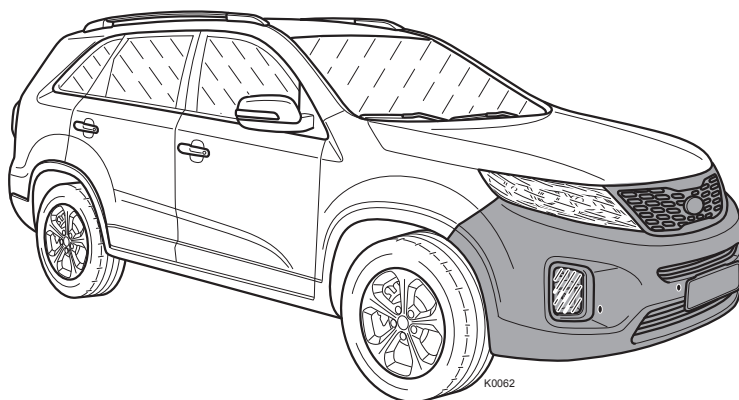

SORENTO 2012

1

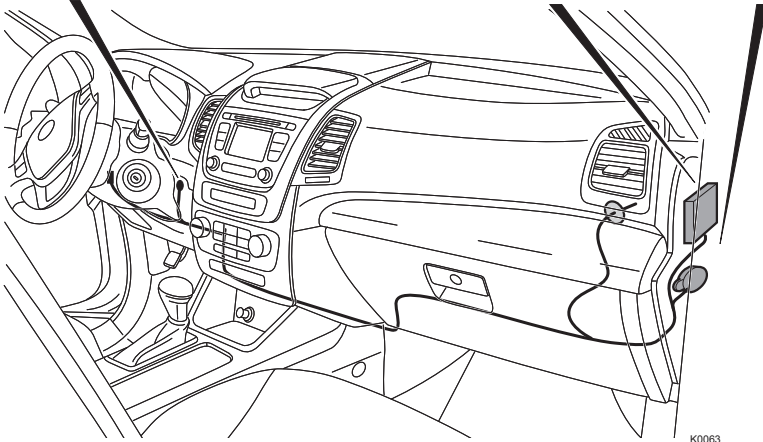
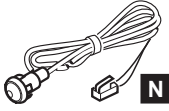

2

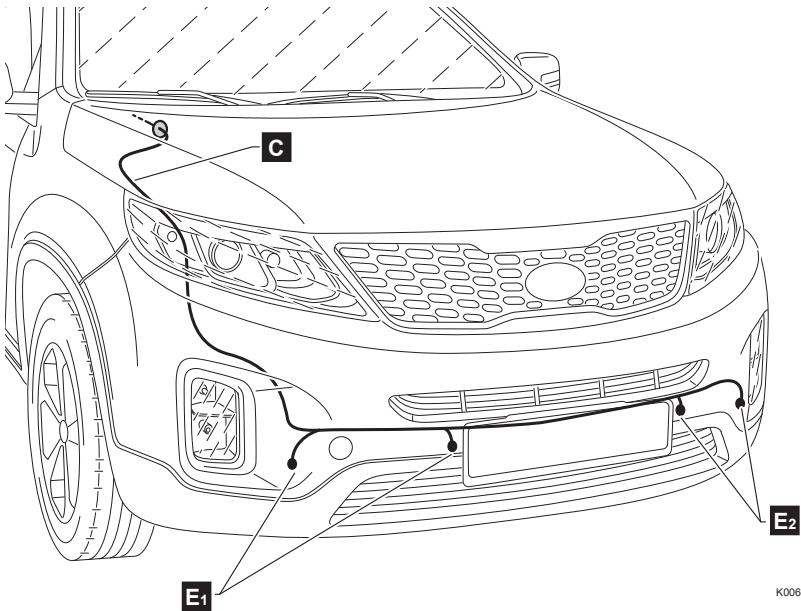

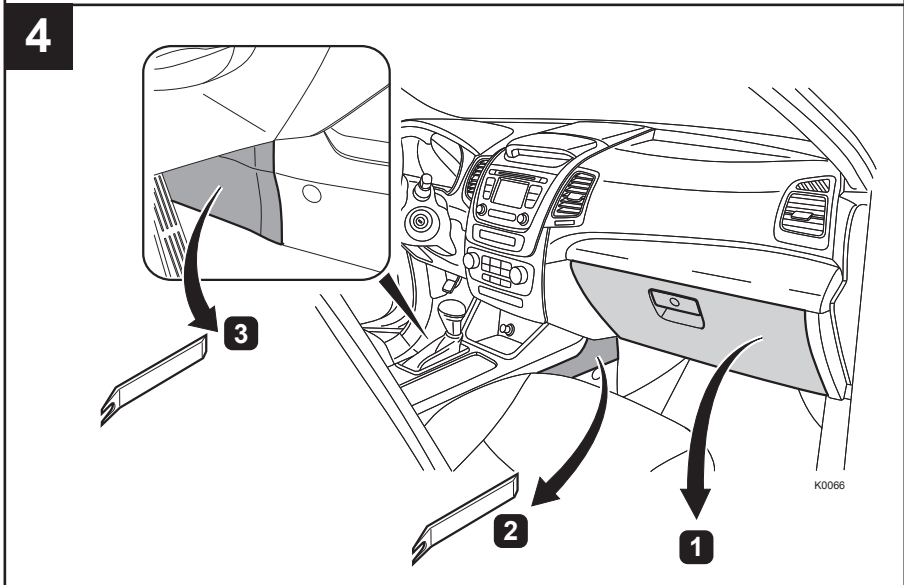
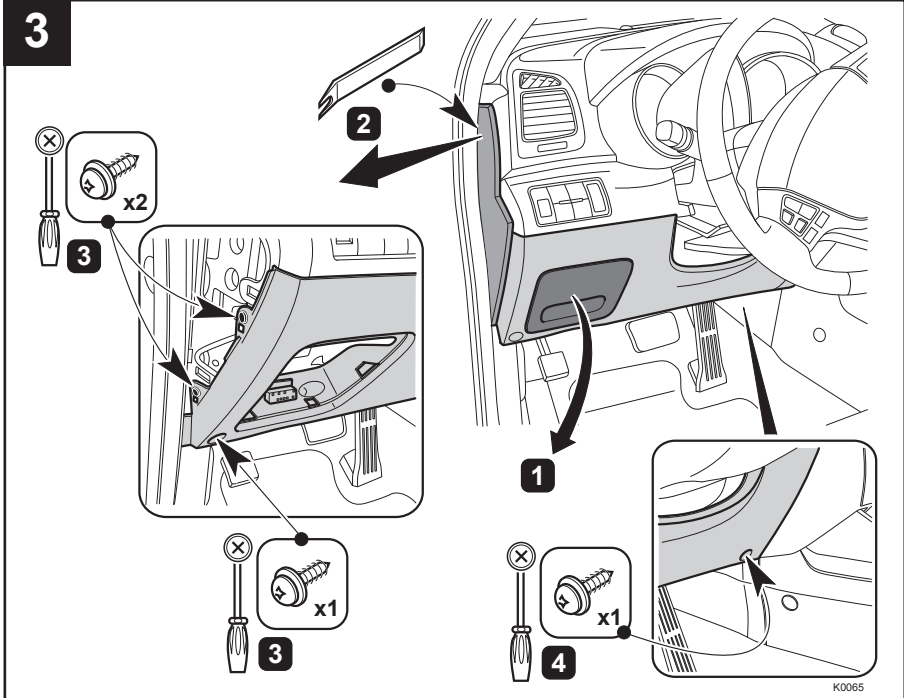

5

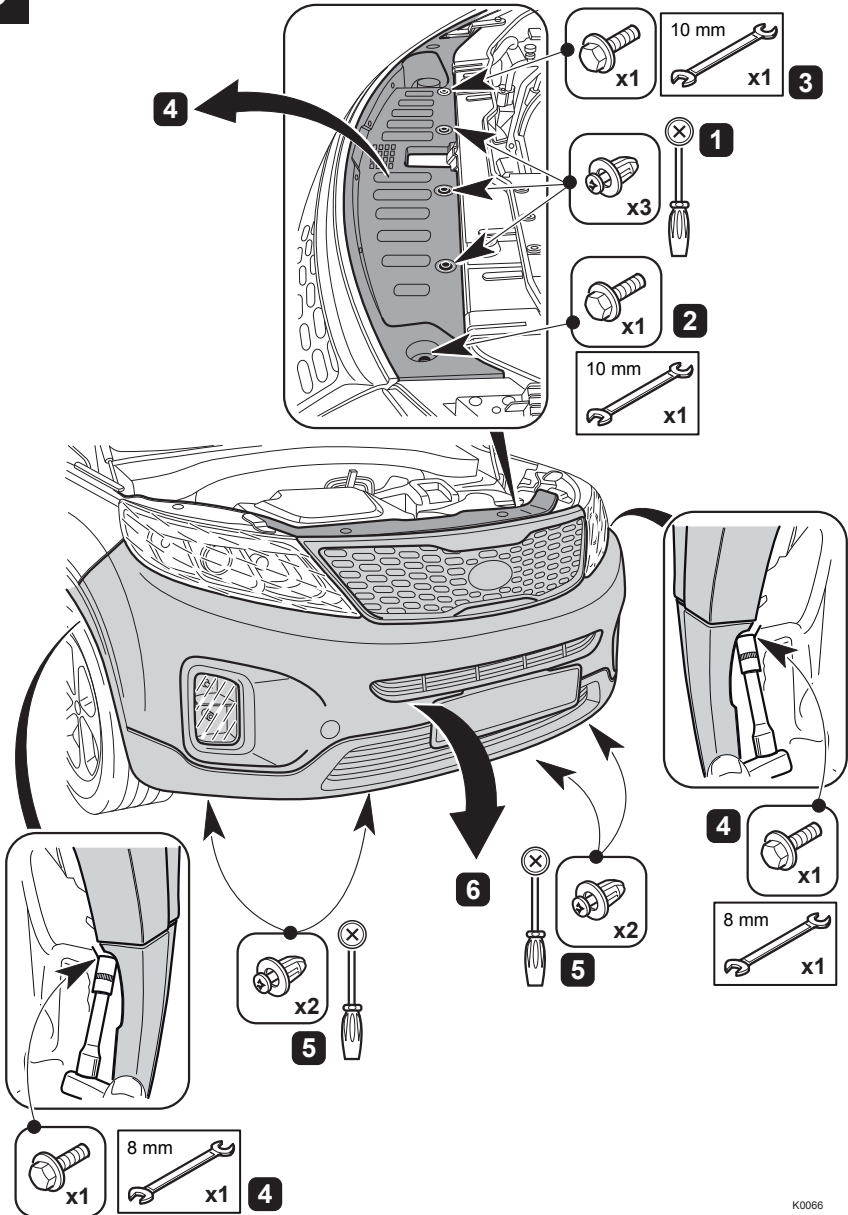

K0066

6

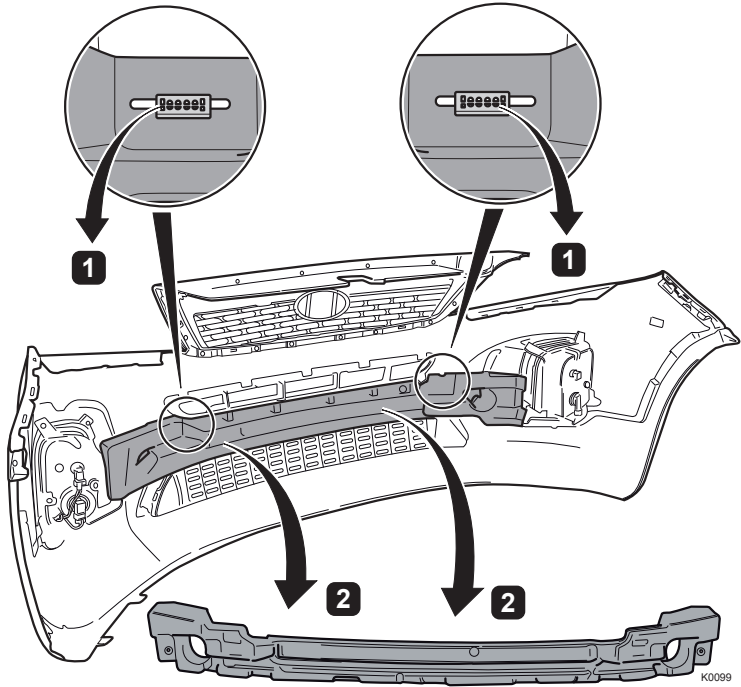

7

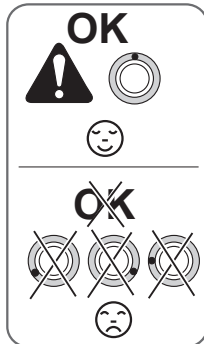
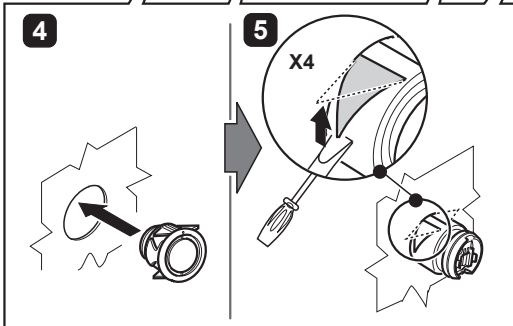
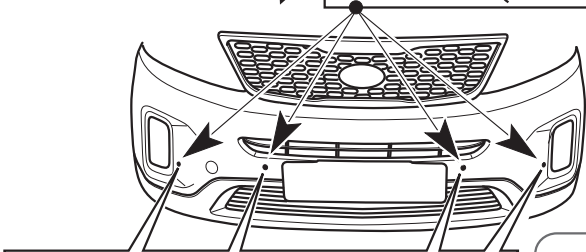
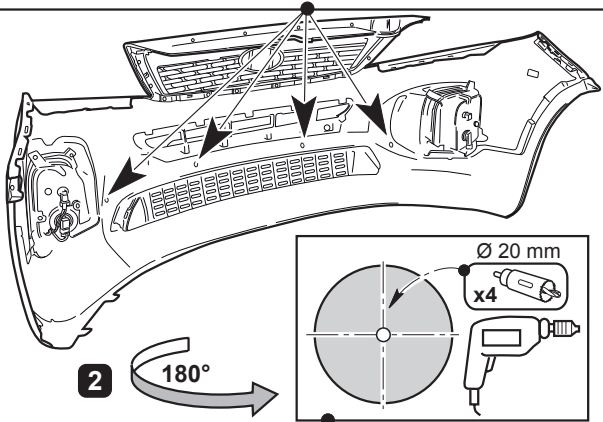
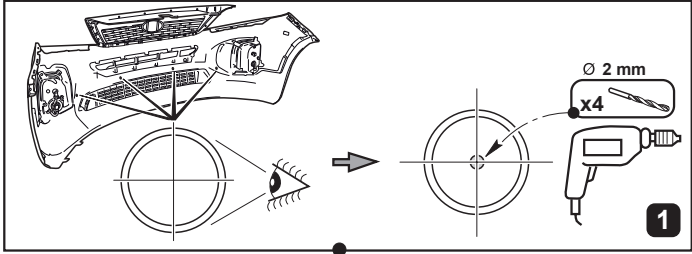

8

9

2

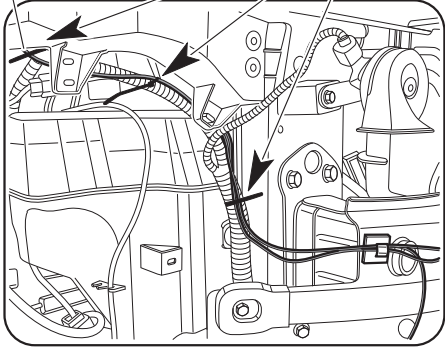
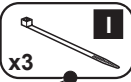

1

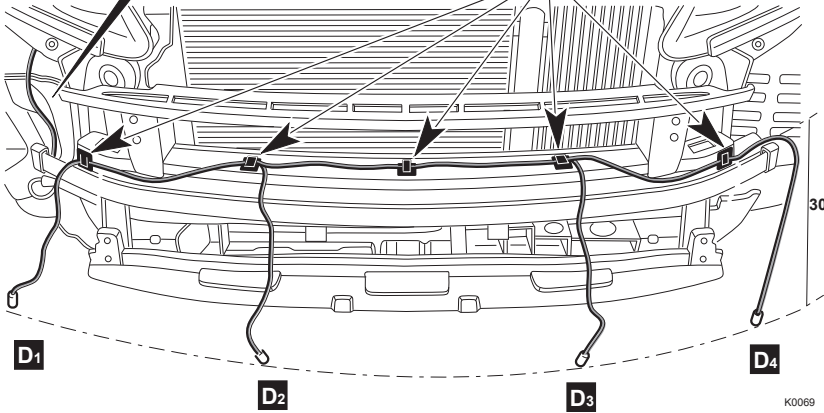

300mm

D1

D2

D3

D4

K0069

9

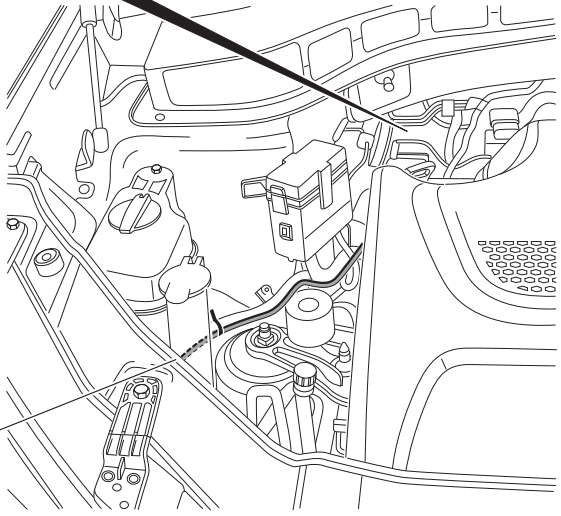
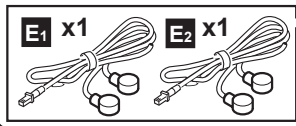
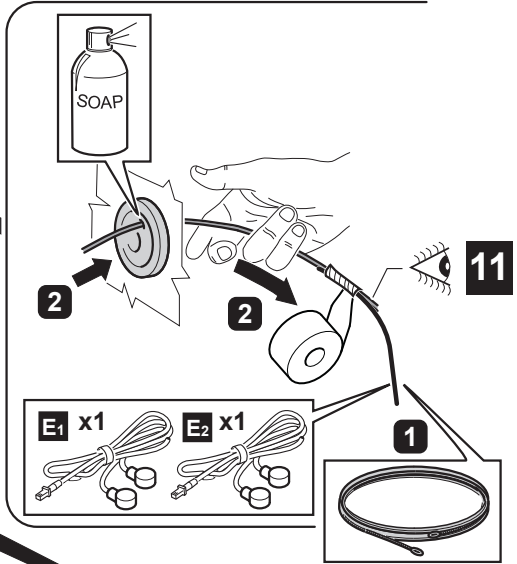
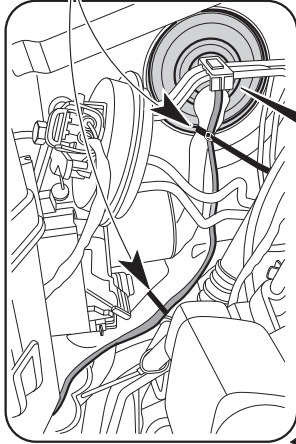

K0070

10

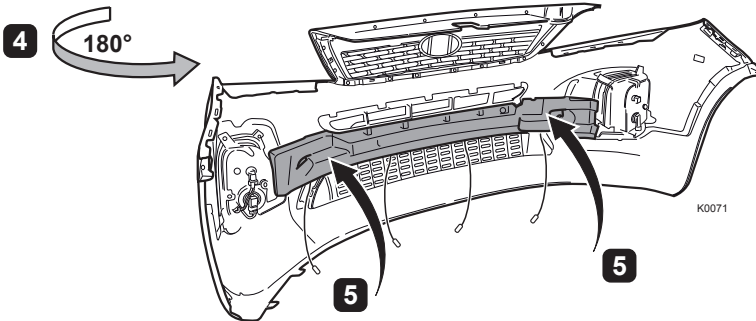
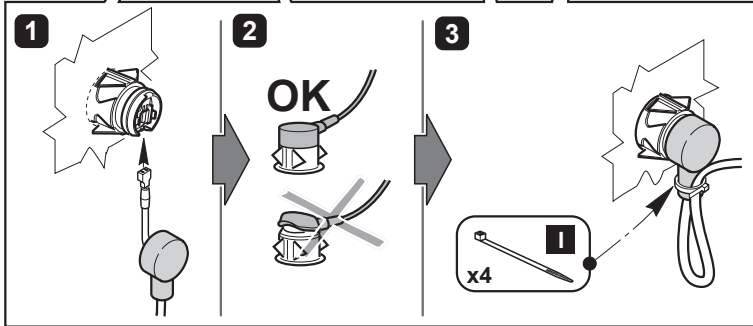
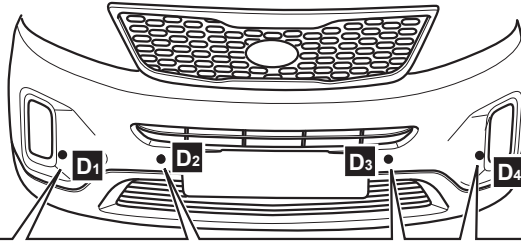

11

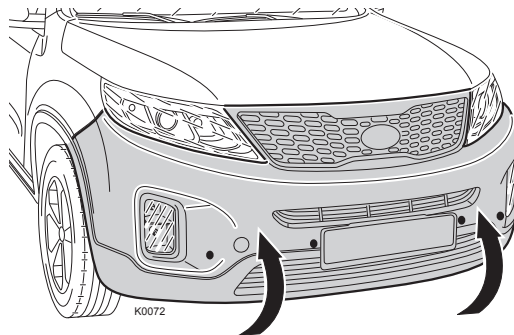

12

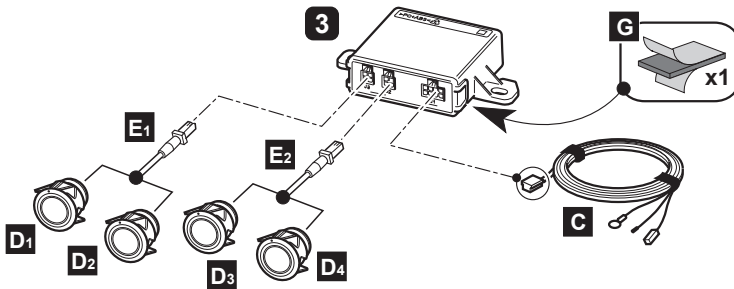
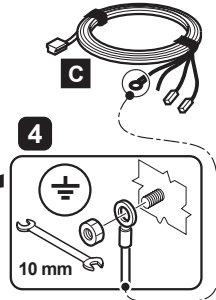
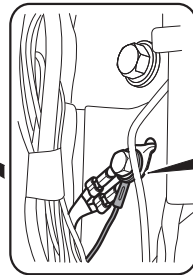
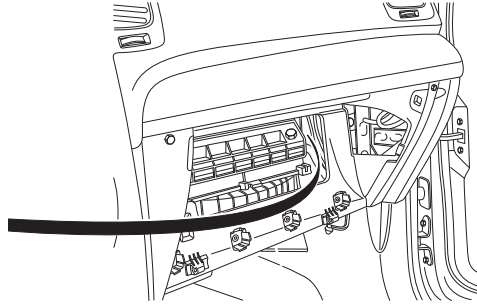
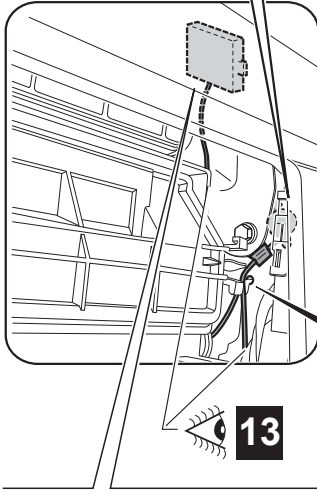
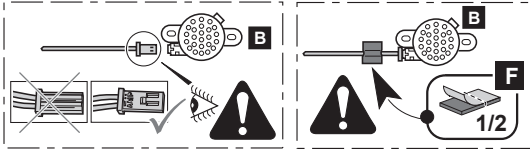
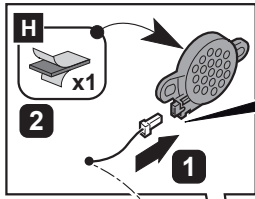

K0073

13

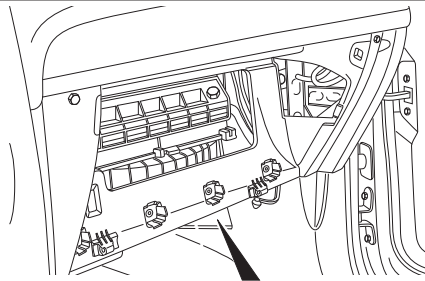

12

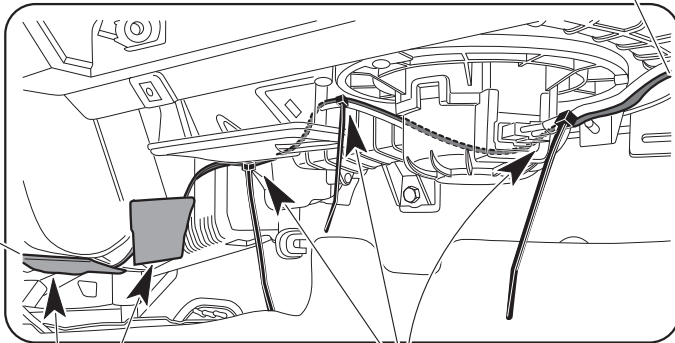

14

14

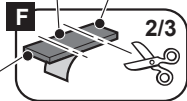

K0074

14



15

16

12

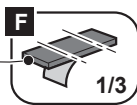
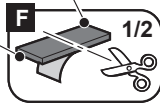
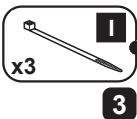

K0076

15

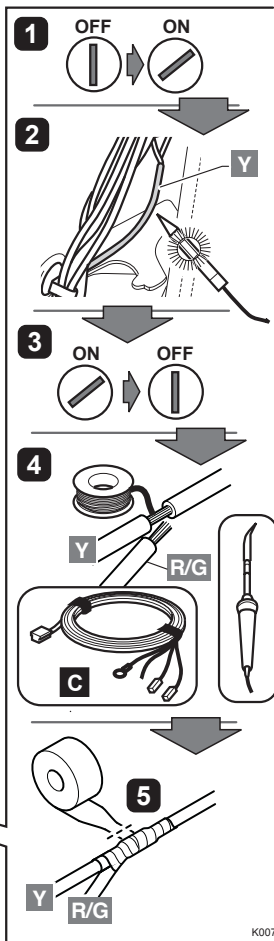
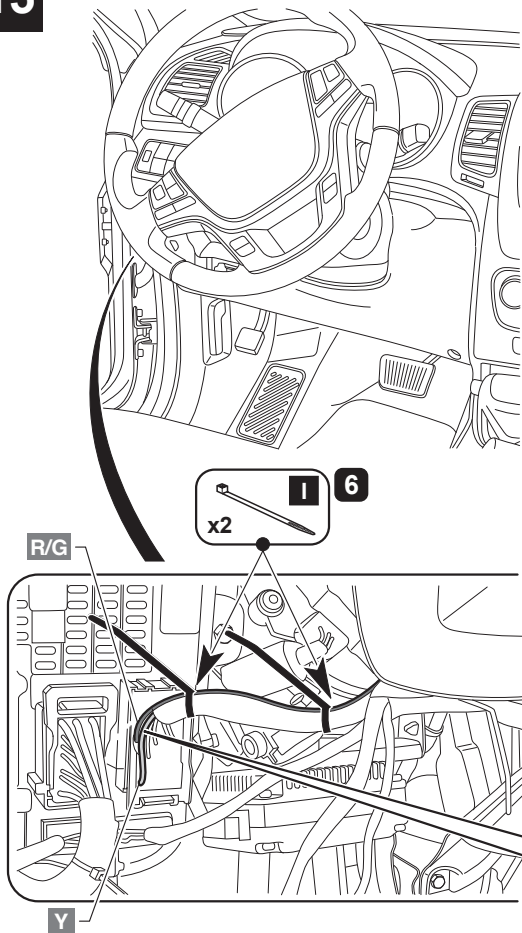

K0075

Y	YELLOW	GELB	JAUNE	GEEL	GUL	GIALLO	GUL
AMARELO	AMARILLO	GUL	ŽLUTÁ	KELTAINEN	ŽÓLTY	ЖЕЛТЫЙ	ŽLTÁ
R	RED	ROT	ROUGE	ROOD	RÓD	ROSSO	ROD
VERMELHO	ROJO	ROD	ČERVENÁ	PUNAINEN	CZERWONY	КРАСНЫЙ	ČERVENÝ
G	GREEN	GRÜN	VERT	GROEN	GRØN	VERDE	GRØNN
VERDE	VERDE	GRÖN	ZELENÁ	VIHREÄ	ZIELONA	ЗІЛІНІ	ZELENÁ



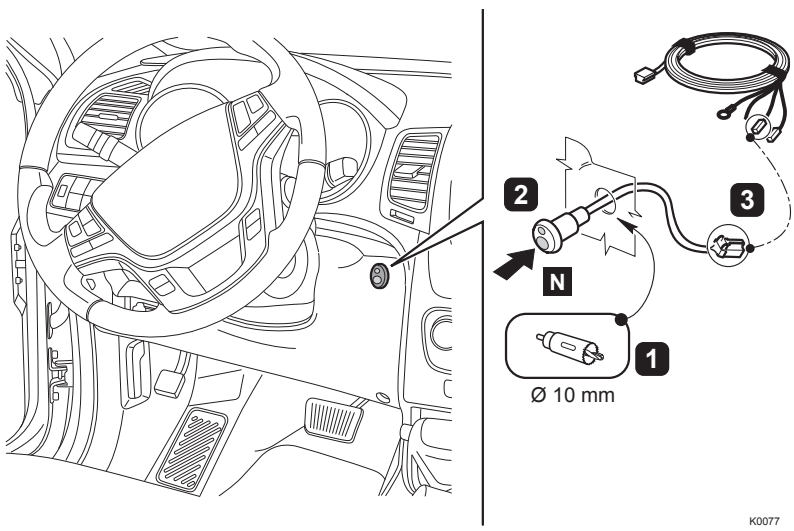

15



K0077

16

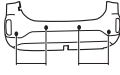
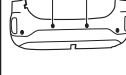
SETUP

	sensitivity 			 
1	2	2	4	

K0078



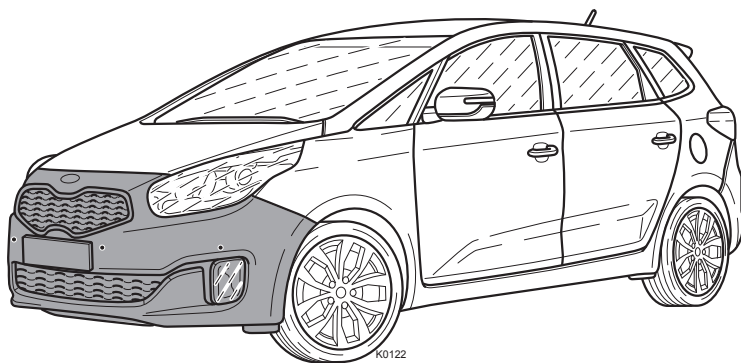

CARENS 2013

1

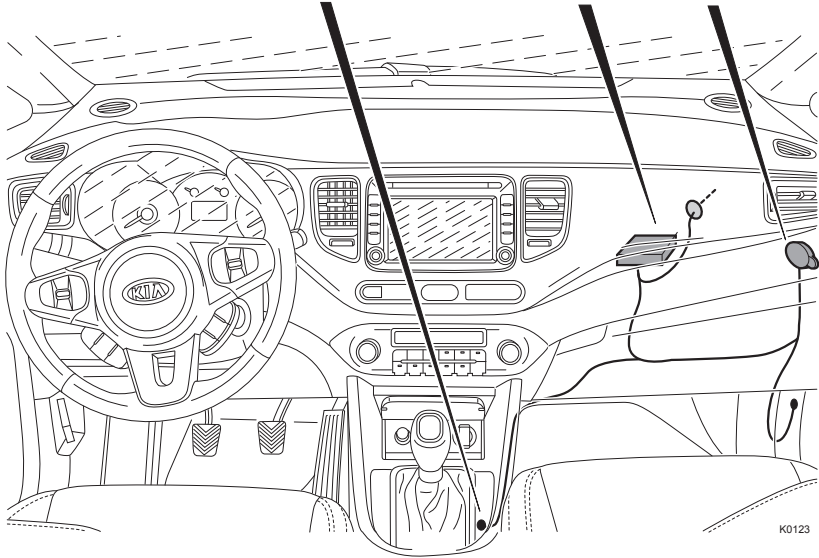

K0123

2

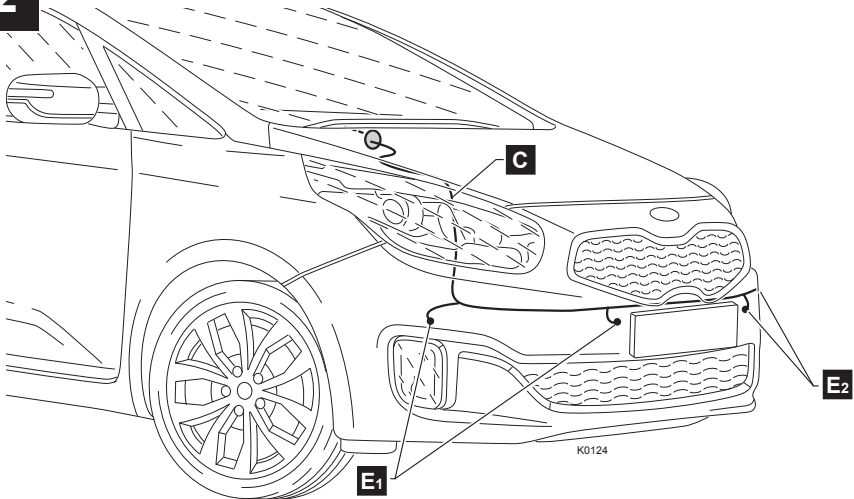

K0124

3

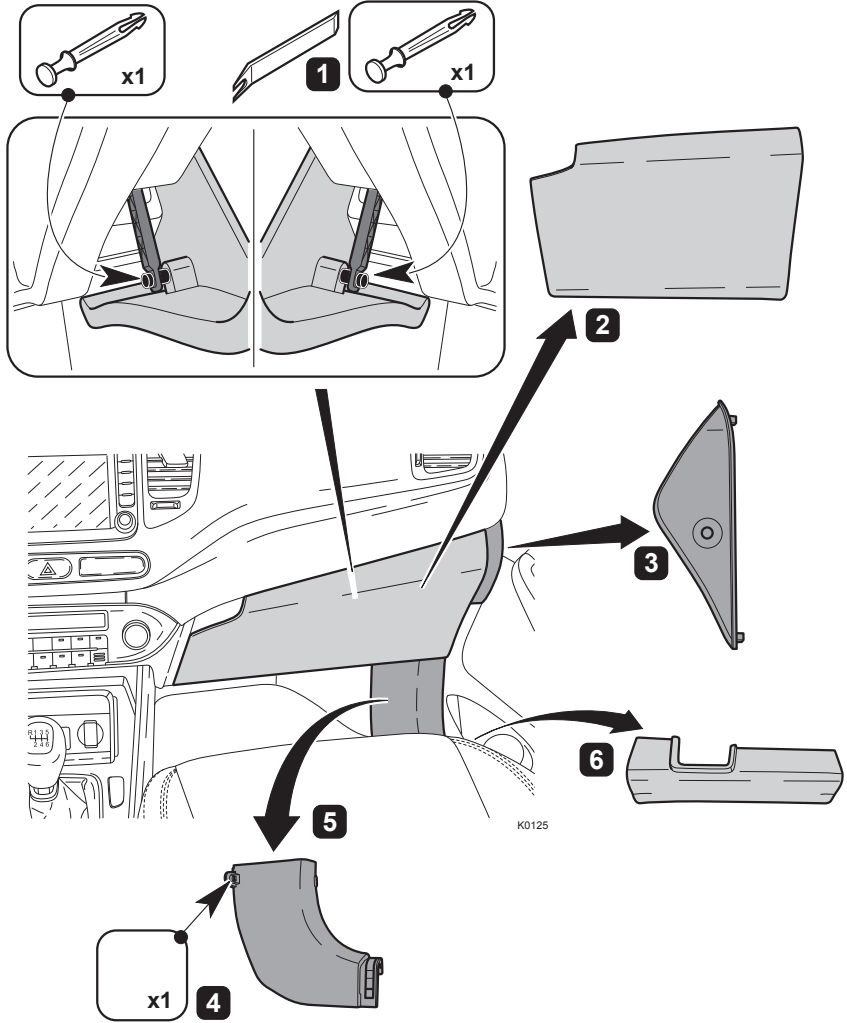

4

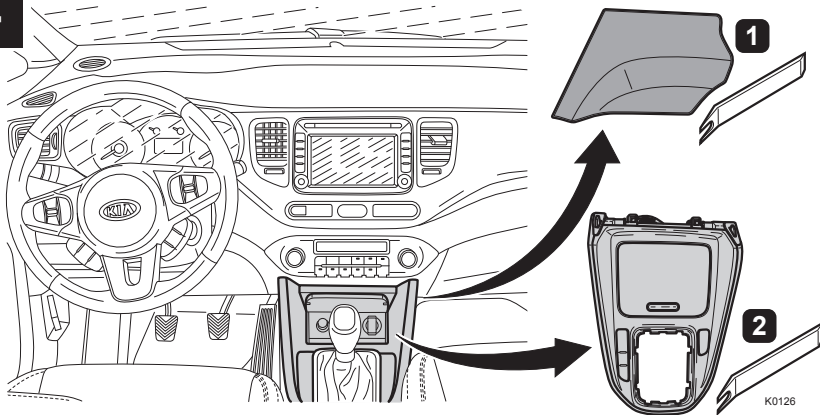

5

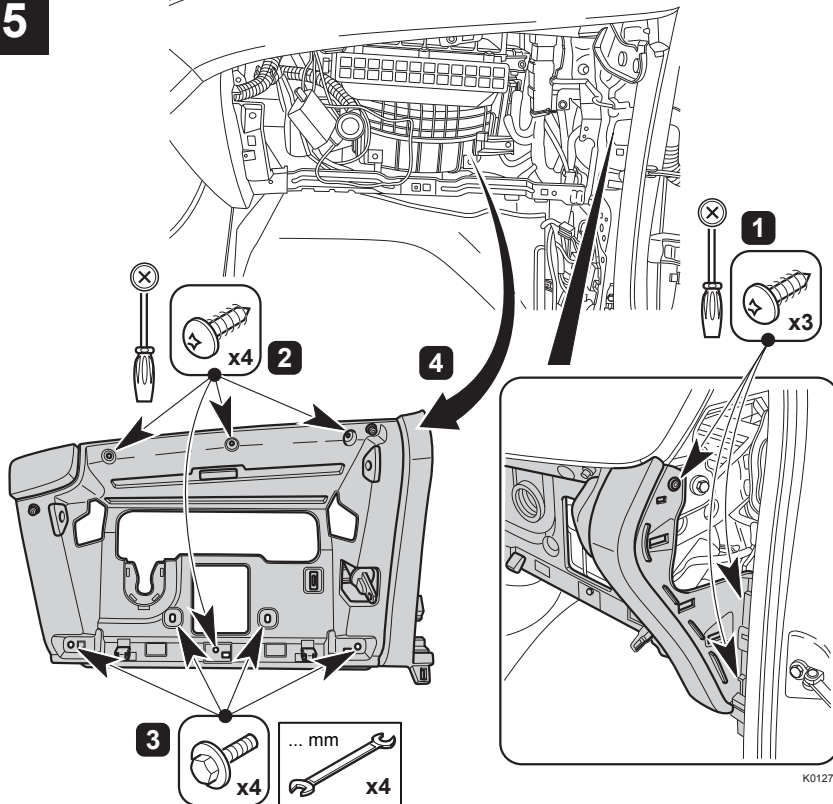

6

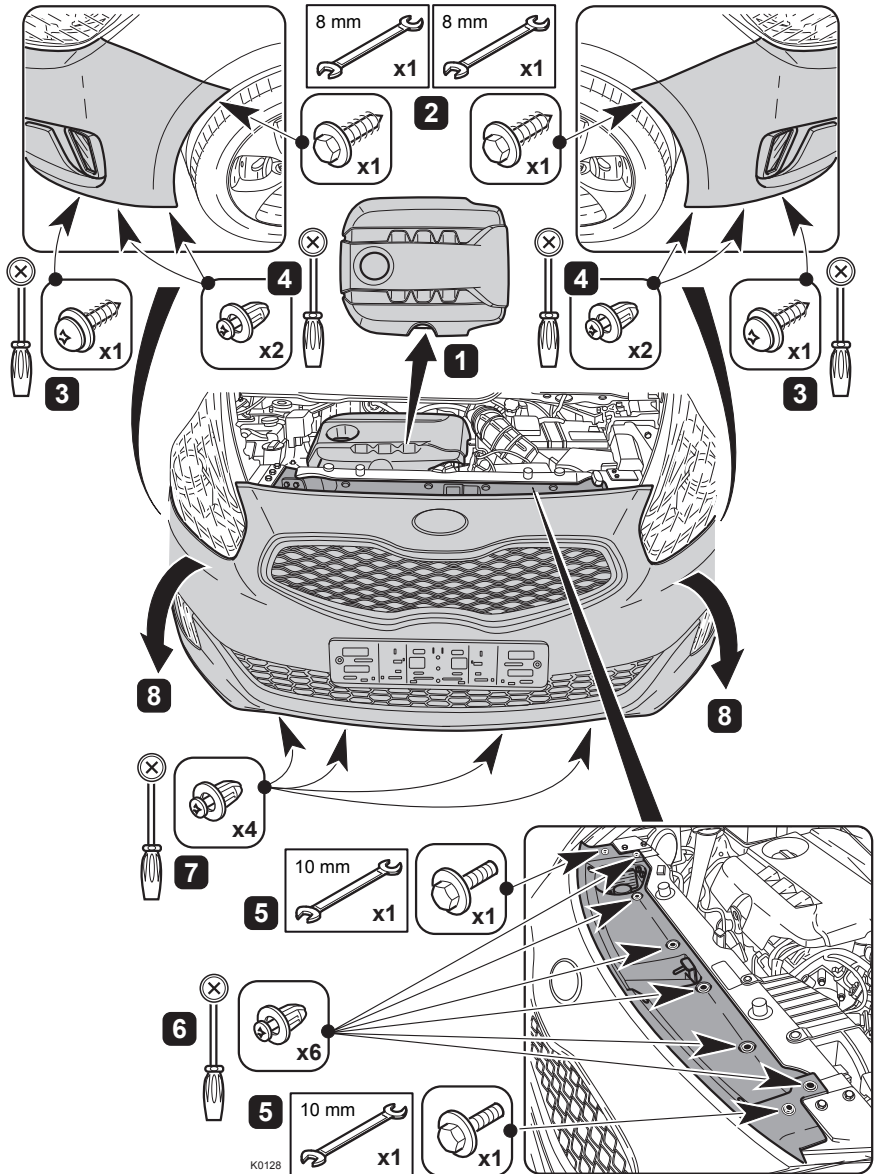

7

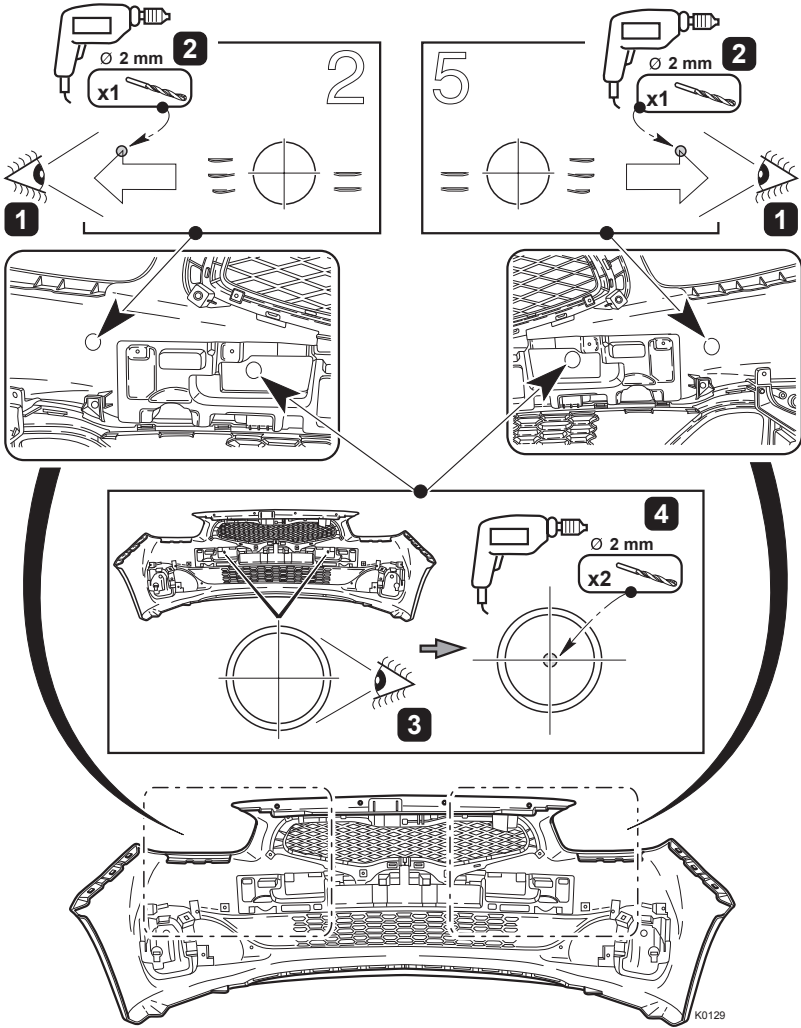

8

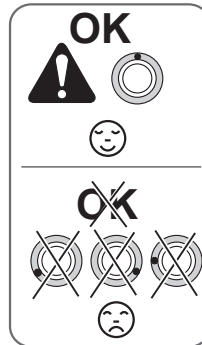
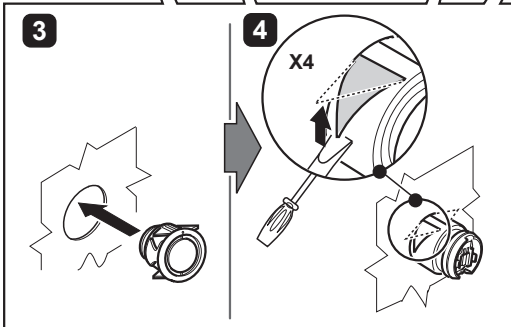
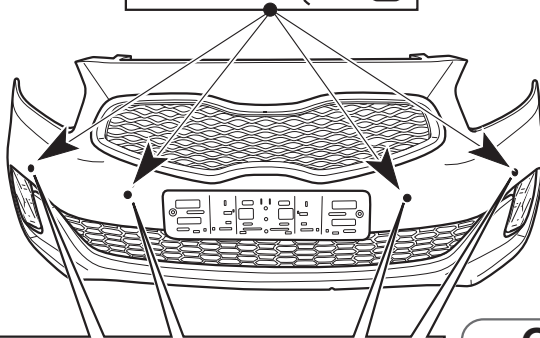
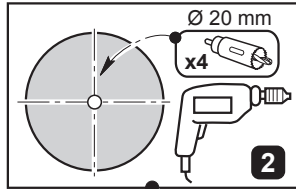

K0130

9

1

x4 K

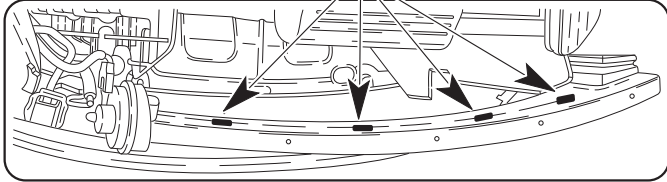

10

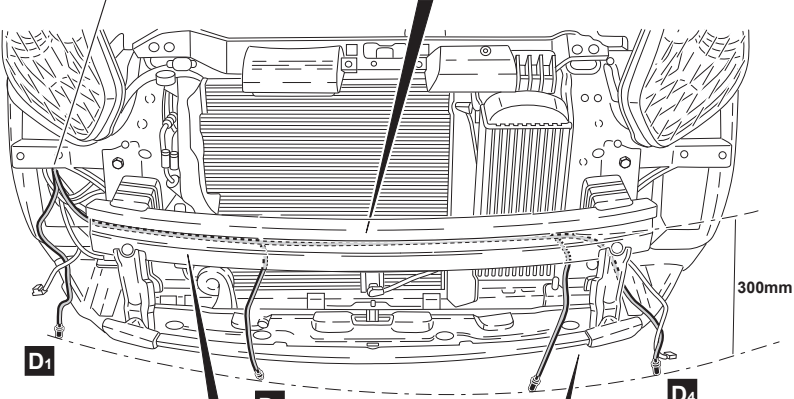

300mm

2

x4 I

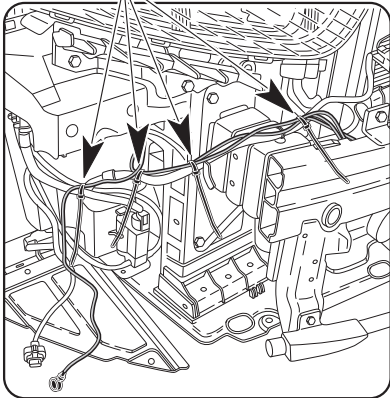

2

x1 I

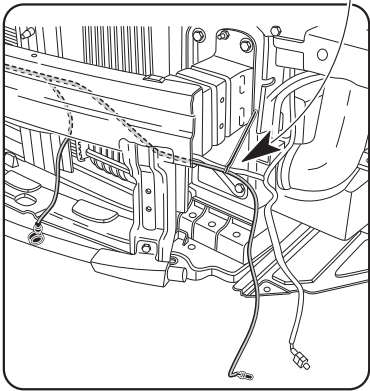

K0131

10

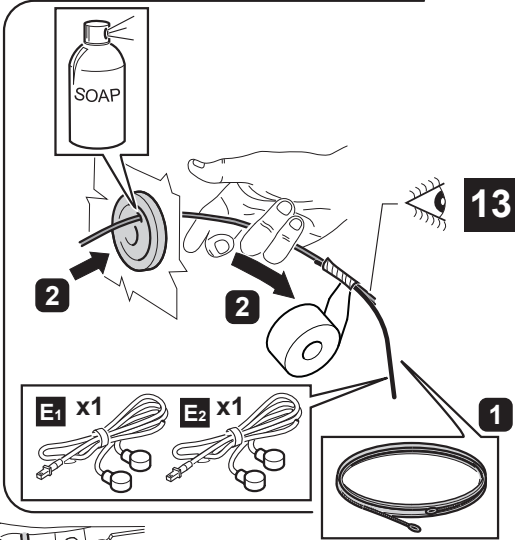
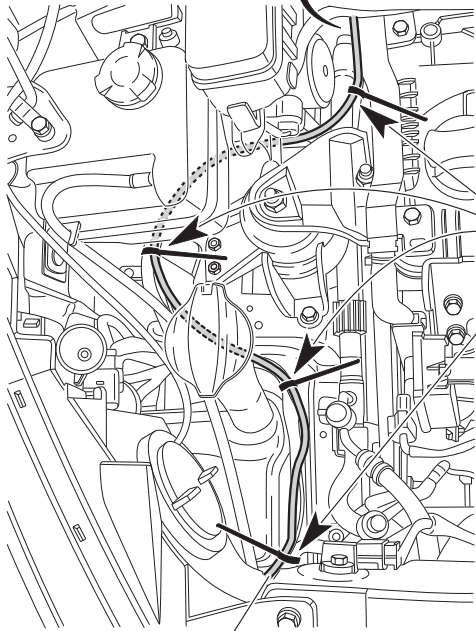

9

K0132

3

x4

1

11

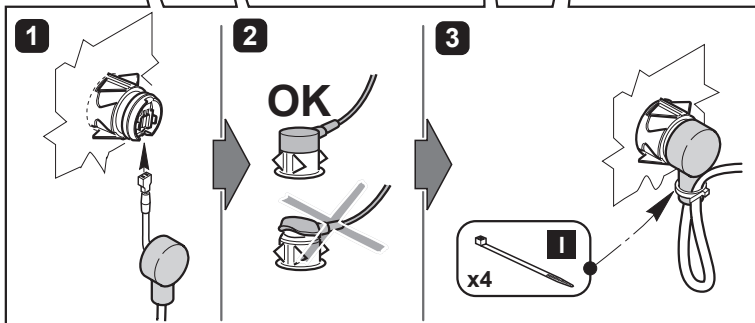
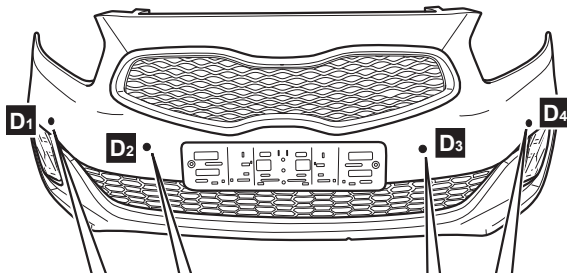

K0133

12

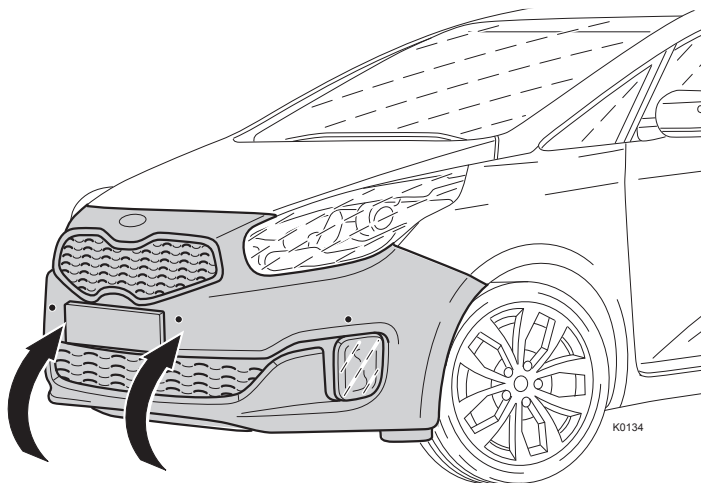

K0134

13

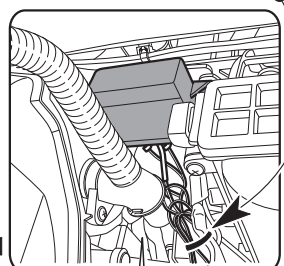
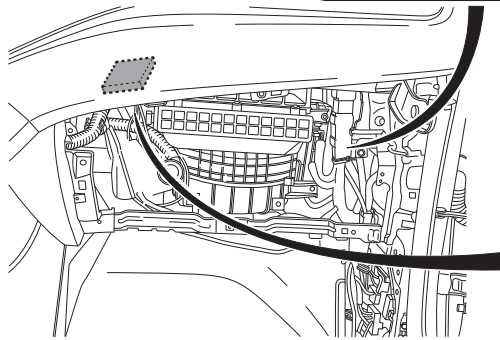
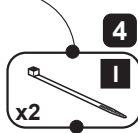
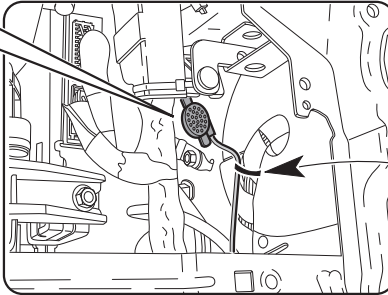
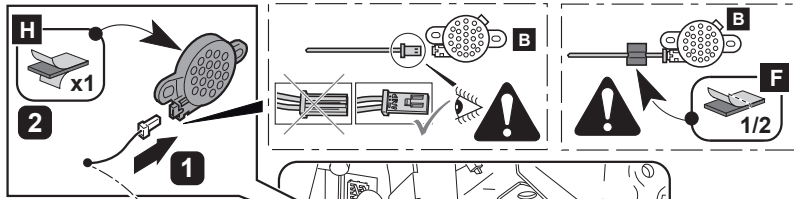

14

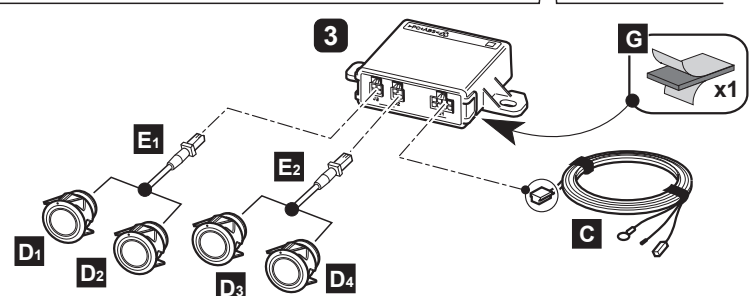

K0135

14

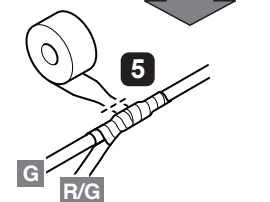
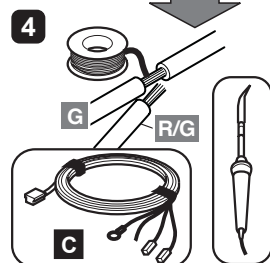
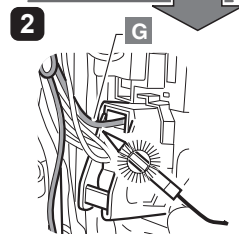
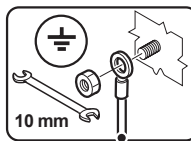
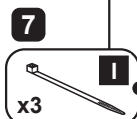
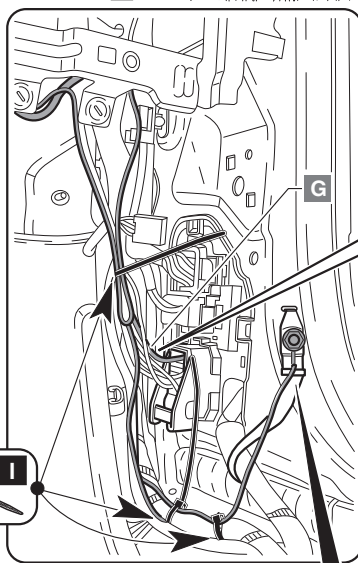
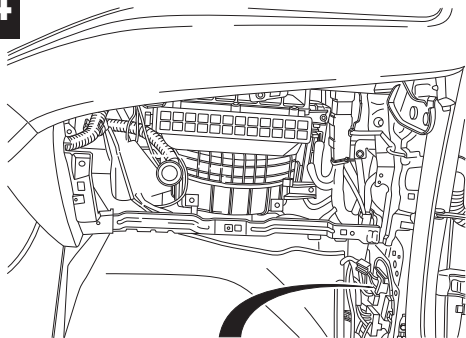

K0136

R	RED	ROT	ROUGE	ROOD	ROD	ROSSO	ROD
VERMELHO	ROJO	ROD	ČERVENÁ	PUNAINEN	CZERWONY	КРАСНЫЙ	ČERVENÝ

G	GREEN	GRÜN	VERT	GROEN	GRØN	VERDE	GRØNN
VERDE	VERDE	GRÜN	ZELENÁ	VIHREÄ	ZIELONA	ЗІЛЕНІЙ	ZELENÁ

16

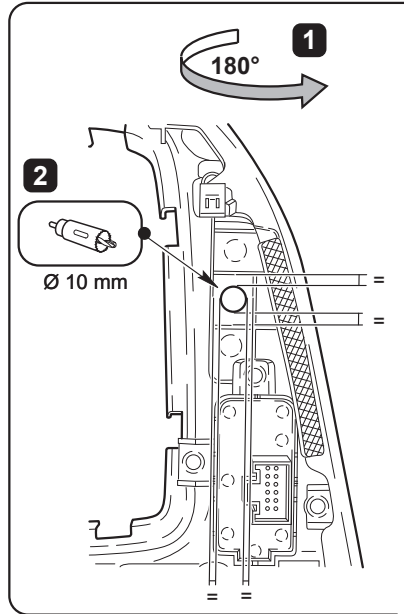
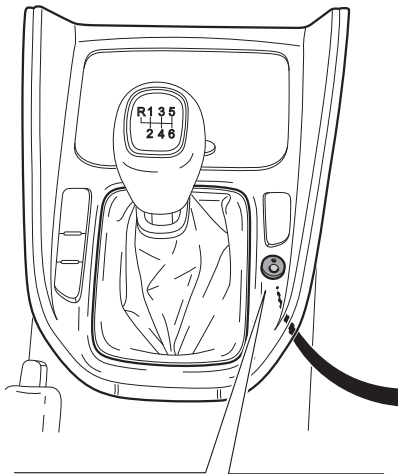

K0137

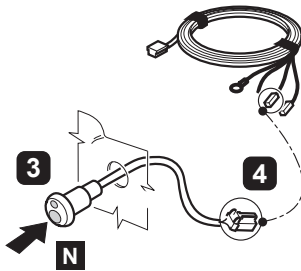

17

SETUP

	sensitivity		
1	3	2	4



K0138



A large rectangular area containing 25 horizontal lines, intended for writing or drawing.



A large rectangular frame containing 25 horizontal lines, intended for writing or drawing.

